



ArcelorMittal

ArcelorMittal Rails & Special Sections



**Railway Accessories**

# Our Company

ArcelorMittal is the world's leading steel and mining company, with over 158.000 employees in more than 60 countries, and annual steel capacity production of 82.7 million tonnes.

ArcelorMittal is the leader in all major global steel markets, including automotive, construction, household appliances, packaging and rails, with leading R&D and technology, as well as sizeable captive supplies of raw materials and outstanding distribution networks. With an industrial presence in Europe, Asia, Africa and America, ArcelorMittal covers all of the key steel markets, from emerging to mature. With production sites in Gijón (Spain), Dabrowa Górnicza and Chorzów (Poland), as well as in Rodange (Luxembourg), ArcelorMittal is part of a small group of rail manufacturers whose production has developed notably in the specialised high-speed and heavy transport sectors.

ArcelorMittal has implemented and keeps updated a quality assurance system that complies with the requirements of the international standard ISO 9001, and is certified by AENOR, the Spanish Association for Standardisation and Certification, a member of IQNet, the international network of organisations for the evaluation and certification of quality systems. ArcelorMittal Poland and ArcelorMittal Rodange are both ISO 9001 certificated

## Contents

- 4 | Ribbed baseplates
- 13 | Tie plates type Pandrol
- 14 | Tie plates inclined
- 16 | Tie plates standard
- 19 | Clamps
- 20 | Fishplates
- 23 | Frog profile
- 24 | Metro guide BAR
- 25 | Base plates
- 26 | Strengthened fishplates





### Achieving carbon-neutral steelmaking

ArcelorMittal Europe has committed to reduce CO2 emissions by 35% by 2030, with a further ambition to be carbon neutral by 2050, in line with the EU's Green Deal and the Paris Agreement.

As the leading global steel company, we are engaged in the most important challenge faced by the industry – that of producing all the steel the world needs in an environmentally sustainable way.

XCarb™ is the new brand name for ArcelorMittal's ongoing global programme of steelmaking innovation targeted at carbon-neutral steel by 2050. The initiatives that are part of XCarb™ aim to reduce the carbon footprint of ArcelorMittal and of our customers.

Our first XCarb™ products are now ready for market: XCarb™ green steel certificates, which are designed for our steel products made from iron ore, and XCarb™ recycled and renewably produced for steel products made via the electric arc furnace route using scrap steel and 100% renewable energy.

# Ribbed baseplates

From section KRph1

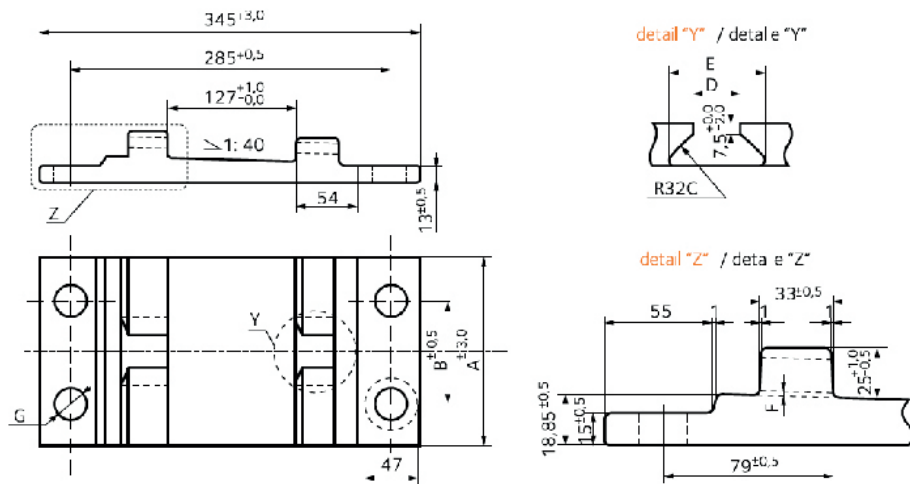

TYPE OF BASEPLATE	DIMENSIONS (mm)							THEORETICAL WEIGHT (KG)		
	A	B	C	D	E	F	G	With 4 holes	With 2 holes	With no holes
Rph1-110-2	110	-	+1,0 -0,5	28±1,0	56,5 <sup>+3,0</sup> -0,5	0 <sup>+1,0</sup> -0,0	Ø26±0,8	-	5,28	-
RpIV-110*	110	-	+0,5 -0,0	27±0,5	56,5±1,0	0,5 <sup>+1,0</sup> -0,0	-	-	-	5,435
Rph1-140/4/25	140	80	+1,0 -0,5	28±1,0	56,5 <sup>+1,5</sup> -0,5	0 <sup>+1,0</sup> -0,0	Ø25±0,2	6,79	-	-
Rph1-150	150	90	+1,0 -0,5	28±1,0	56,5 <sup>+3,0</sup> -0,5	0 <sup>+1,0</sup> -0,0	Ø26±0,8	7,328	7,445	-
RpIV-150	150	90	+0,5 -0,0	27±0,5	56,5±1,0	0,5 <sup>+1,0</sup> -0,0	Ø24 <sup>+1,0</sup> -0,0	7,35	-	-
RpIV	160	90	+0,5 -0,0	27±0,5	56,5±1,0	0,5 <sup>+1,0</sup> -0,0	Ø24 <sup>+1,0</sup> -0,0	7,86	-	-
Rph1-160	160	90	+1,0 -0,5	28±1,0	56,5 <sup>+3,0</sup> -0,5	0 <sup>+1,0</sup> -0,0	Ø26±0,8	7,857	7,97	-
Rph1-160/2d/36	160	90	+1,0 -0,5	28±1,0	56,5 <sup>+3,0</sup> -0,5	0 <sup>+1,0</sup> -0,0	Ø36 <sup>+1,0</sup> -0,0	-	7,88	-
Rph1-160/79/2/33	160	-	+1,0 -0,5	28±1,0	56,5 <sup>+3,0</sup> -0,5	0 <sup>+1,0</sup> -0,0	Ø33 <sup>+0,8</sup> -0,2	-	7,89	-
Rph1-170/285x90/4/24	170	90	+1,0 -0,5	28±1,0	56,5 <sup>+3,0</sup> -0,5	0 <sup>+1,0</sup> -0,0	Ø24 <sup>+1,0</sup> -0,0	8,44	-	-
Rph1-180/26	180	90	+1,0 -0,5	28±1,0	56,5 <sup>+3,0</sup> -0,5	0 <sup>+1,0</sup> -0,0	Ø26±0,8	8,95	-	-
Rph1-210/26	210	90	+1,0 -0,5	28±1,0	56,5 <sup>+3,0</sup> -0,5	0 <sup>+1,0</sup> -0,0	Ø26±0,8	10,549	10,67	-
Rph1-210/285x150	210	150	+1,0 -0,5	28±1,0	56,5 <sup>+3,0</sup> -0,5	0 <sup>+1,0</sup> -0,0	Ø36 <sup>+1,0</sup> -0,0 Ø37 <sup>+1,0</sup> -0,0	10,35 10,31	10,56 10,55	-

Besides we produce

From section KRph1

Rph1/HR-160.Pzb17  
RplA-150.Rpla-160.Sph1a

Rps8A from section KRph1

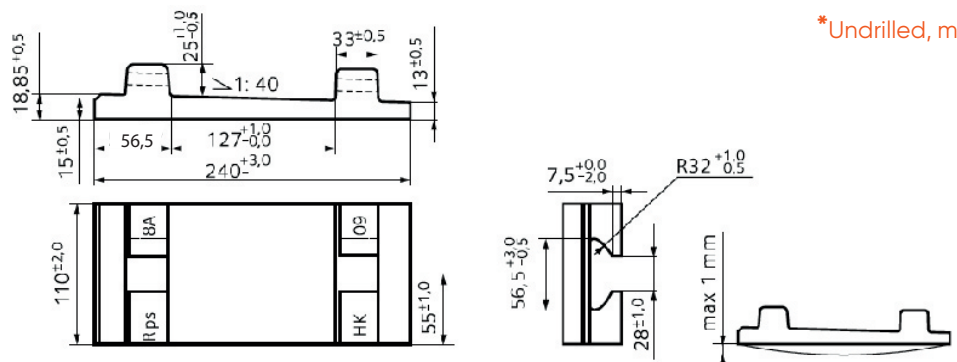

\*Undrilled, milled

From section KRph6

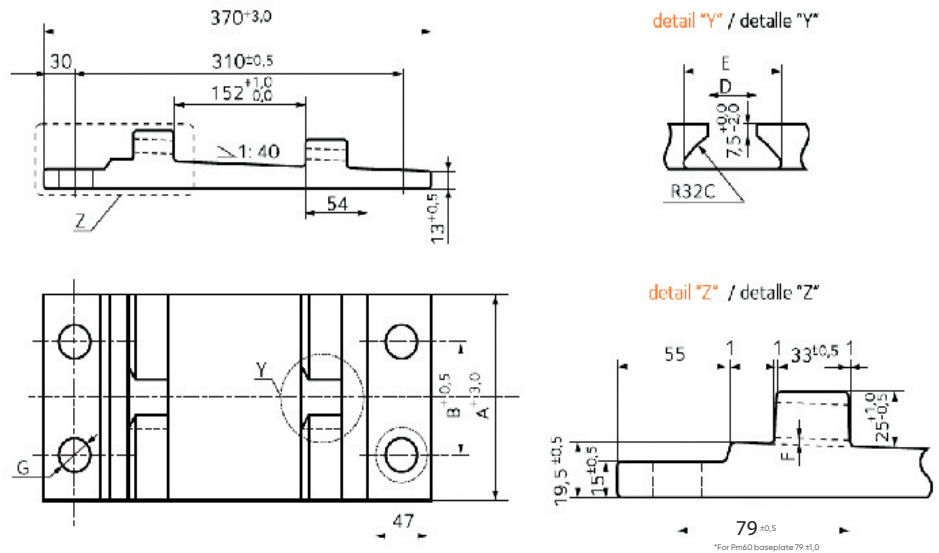

TYPE OF BASEPLATE	DIMENSIONS (mm)							THEORETICAL WEIGHT (KG)	
	A	B	C	D	E	F	G	With 4w holes	With 2 holes
Rph6-150	150	90	+1,0 -0,5	28 ±1,0	56,5 <sup>+3,0</sup> <sub>-0,5</sub>	0 <sup>+1,0</sup> <sub>-0,0</sub>	Ø26 ±0,8	7,88	-
Rph6-160	160	90	+1,0 -0,5	28 ±1,0	56,5 <sup>+3,0</sup> <sub>-0,5</sub>	0 <sup>+1,0</sup> <sub>-0,0</sub>	Ø26 ±0,8	8,44	8,56
RpVI	160	90	+0,5 -0,0	27 ±0,5	56,5 ±1,0	0,5 <sup>+1,0</sup> <sub>-0,0</sub>	Ø24 <sup>+1,0</sup> <sub>-0,0</sub>	8,48	-
Rph6-180/26	180	90	+1,0 -0,5	28 ±1,0	56,5 <sup>+3,0</sup> <sub>-0,5</sub>	0 <sup>+1,0</sup> <sub>-0,0</sub>	Ø26 ±0,8	9,59	9,71
Rph6-210/26	210	90	+1,0 -0,5	28 ±1,0	56,5 <sup>+3,0</sup> <sub>-0,5</sub>	0 <sup>+1,0</sup> <sub>-0,0</sub>	Ø26 ±0,8	11,316	11,433
Pm60	160	90	±0,5	28 <sup>+1,5</sup> <sub>-0,5</sub>	56,5 <sup>+1,5</sup> <sub>-1,0</sub>	0 <sup>+1,0</sup> <sub>-0,0</sub>	Ø26 ±0,5	8,44	-

Basides we produce

From section KRph6

- Rph6/HR-160
- Rpb25
- Rph6-150/4/32
- Rph6-150/2/32
- Rph6-190/4/26

Rph6/Rus-110x265 from section KRph6

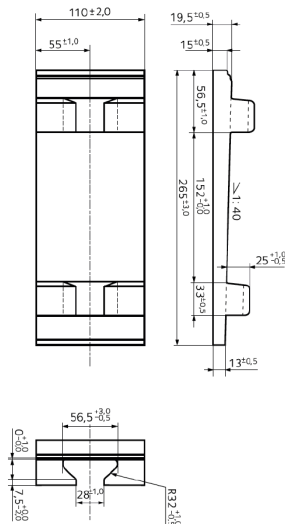

Pz60A from section KRph6

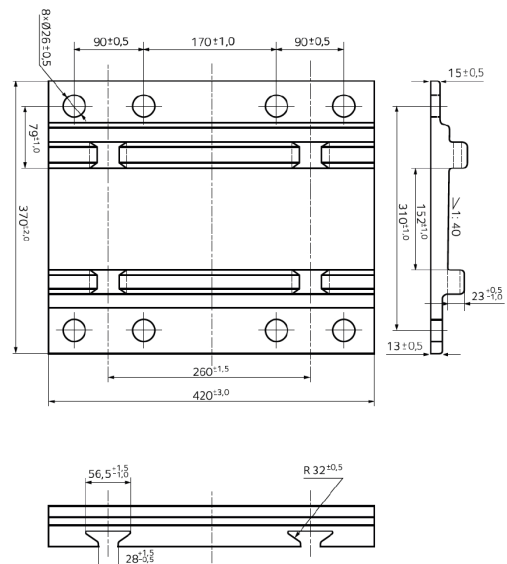

KRph01/01

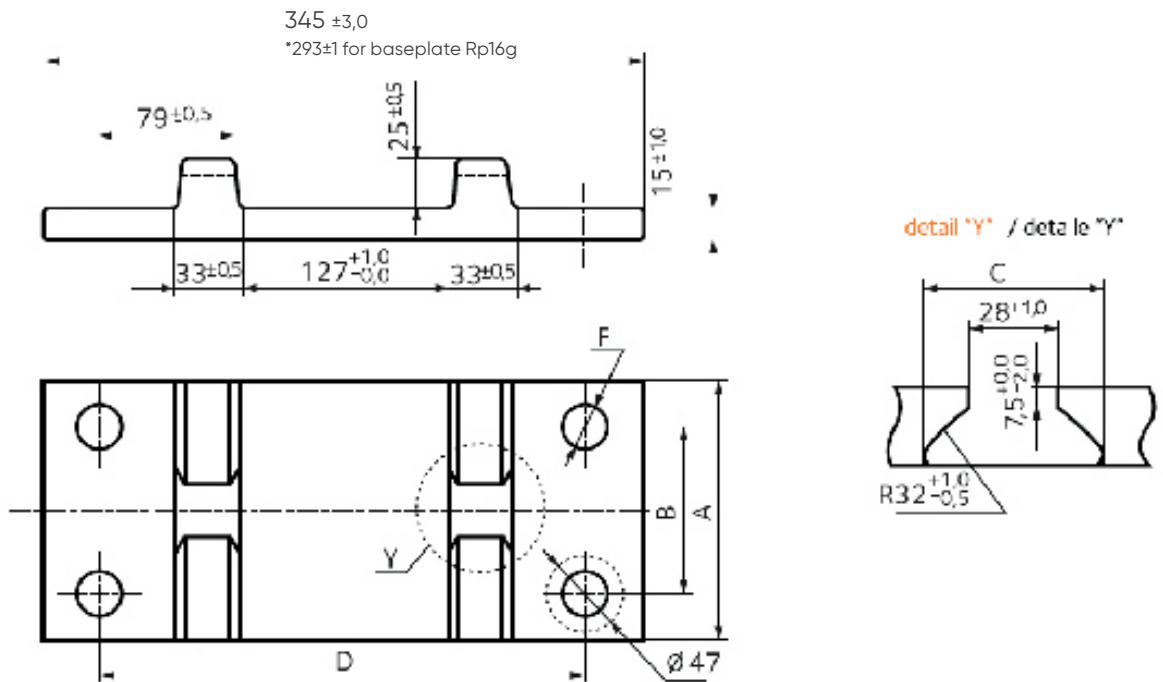

TYPE OF BASEPLATE	DIMENSIONS (mm)					THEORETICAL WEIGHT (KG)
	A	B	C	D	F	
Rp01/01-160	160 ±2,0	94 <sup>+0,5</sup> <sub>-1,0</sub>	56,5 <sup>+3,0</sup> <sub>-0,5</sub>	285±1,0	Ø26±0,8	7,7
Rpb1-160	160 ±2,0	90 <sup>+0,5</sup> <sub>-1,0</sub>	56,5 <sup>+3,0</sup> <sub>-0,5</sub>	285±1,0	Ø26±0,8	7,7
Rp01/01-150	150 ±2,0	94 <sup>+0,5</sup> <sub>-1,0</sub>	56,5 <sup>+3,0</sup> <sub>-0,5</sub>	285±1,0	Ø26±0,8	7,2
Rp01/01-110	110 ±2,0	-	56,5 <sup>+3,0</sup> <sub>-0,5</sub>	285±1,0	Ø26±0,8	5,19
Rpb1-110	110 ±3,0	-	56,5 <sup>+3,0</sup> <sub>-0,5</sub>	285±1,0	Ø26±0,8	5,19
Rp01/02-160	160 ±2,0	94 <sup>+0,5</sup> <sub>-1,0</sub>	56,5 <sup>+3,0</sup> <sub>-0,5</sub>	-	Ø26±0,8	7,83
Rp01/01-210/285x150/4/36	210 ±2,0	150 ±0,5	56,5 <sup>+3,0</sup> <sub>-0,5</sub>	285±1,0	Ø36 <sup>+1,0</sup> <sub>-0,0</sub>	10,12
Rp01/01-140/4/25	140 ±3,0	80 ±0,5	56,5 <sup>+1,5</sup> <sub>-0,5</sub>	285±0,5	Ø25±0,2	6,67
Rp16g*	160 ±2,0	-	56,5 <sup>+3,0</sup> <sub>-0,5</sub>	-	-	7,357
Rp01/03-160*	160 ±2,0	-	56,5 <sup>+3,0</sup> <sub>-0,5</sub>	-	-	7,96
Rp01/09**	160 ±2,0	94 ±0,5	56,5 <sup>+1,5</sup> <sub>-0,5</sub>	285±1,0	Ø26±0,5	7,7
BL3A	112 ±3,0	-	56,5 <sup>+1,5</sup> <sub>-1,0</sub>	285±1,0	Ø26±0,5	5,33

Besides we produce

From section KRph01/01

Rpb1/SBB-160

SRp1A

SRp2 (15<sup>+1,0</sup><sub>-0,0</sub>)

\*Undrilled, milled

\*\*Milling axle dislocated at 25mm

## BL3A from section KRp01/01

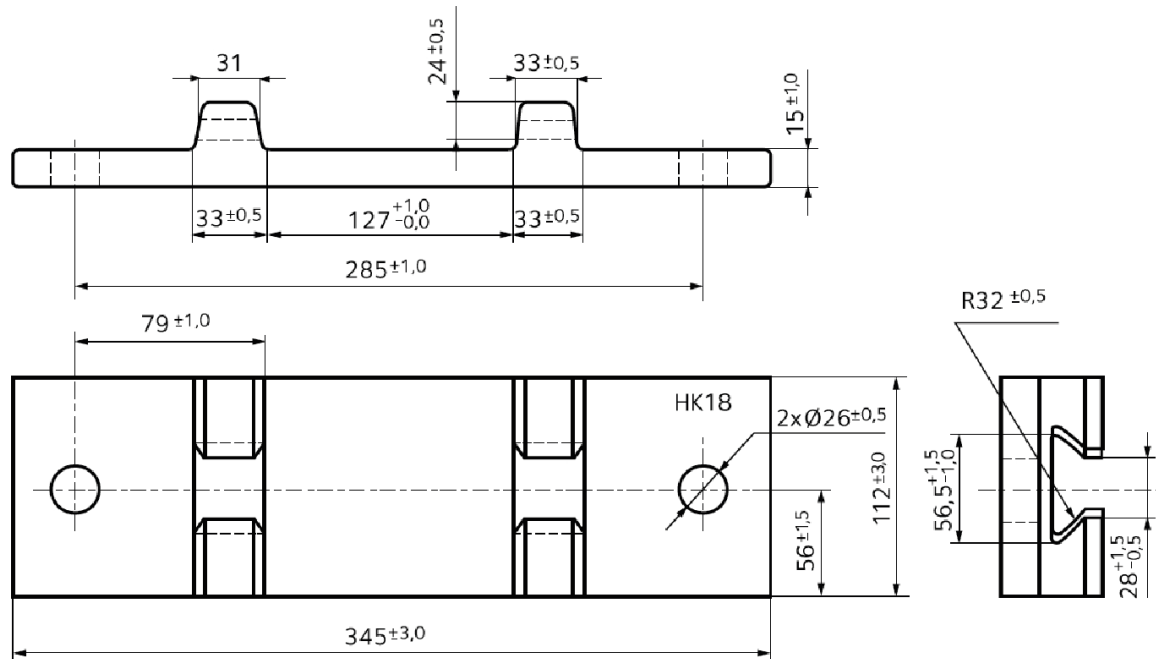

## Pm49 from section KPZ5

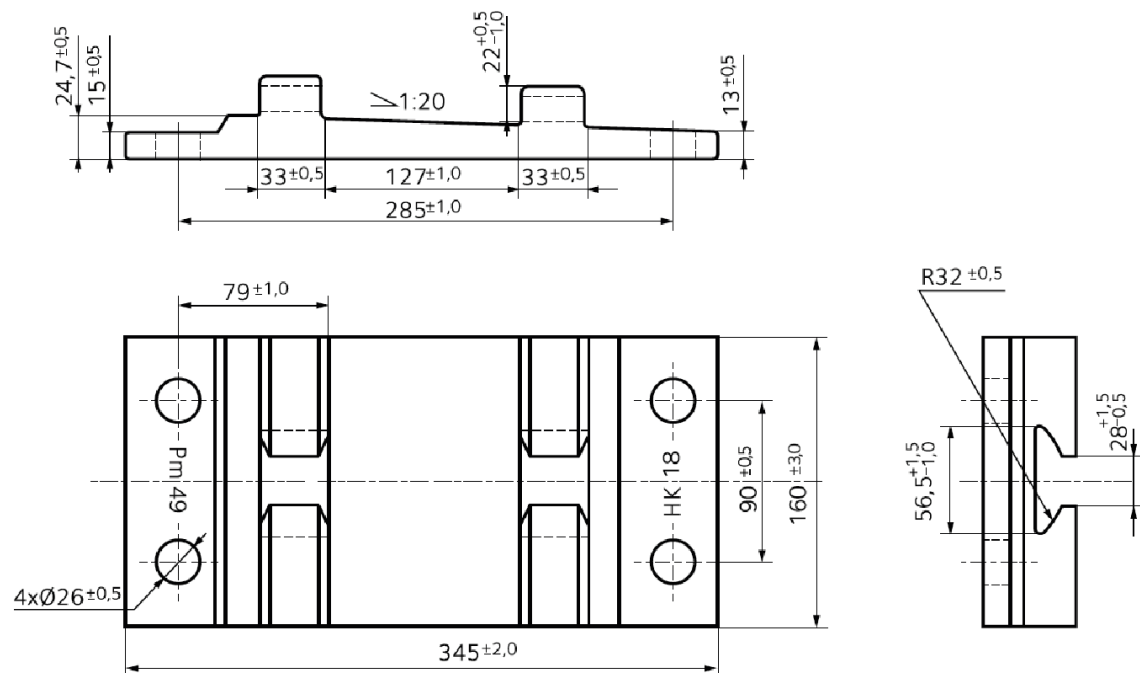

Ps49A from section KRpo21

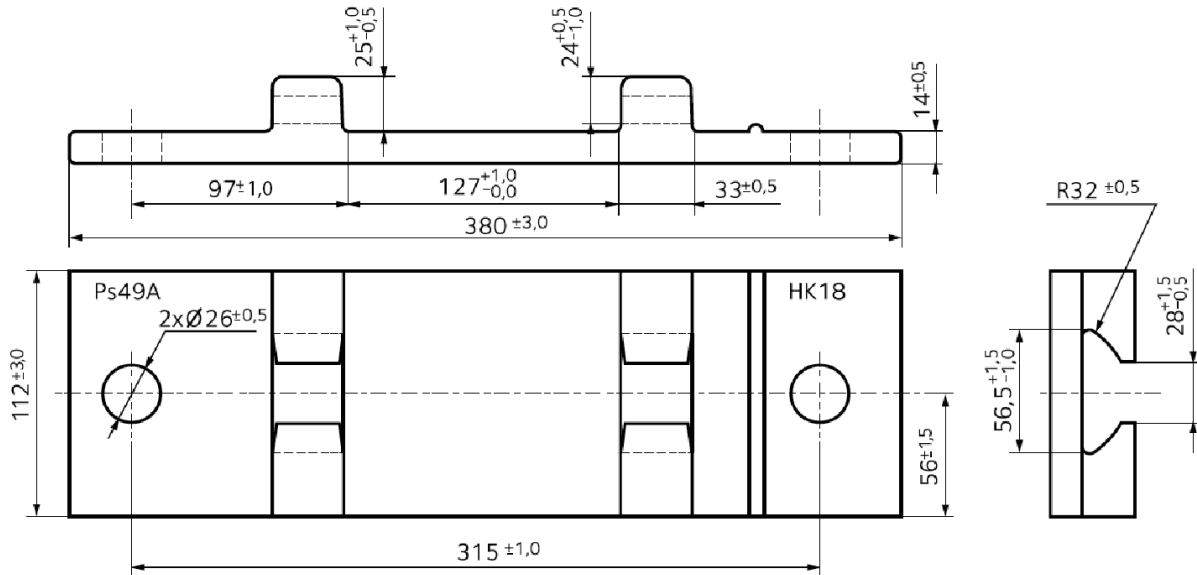

Ps60-112 from section KPZ3

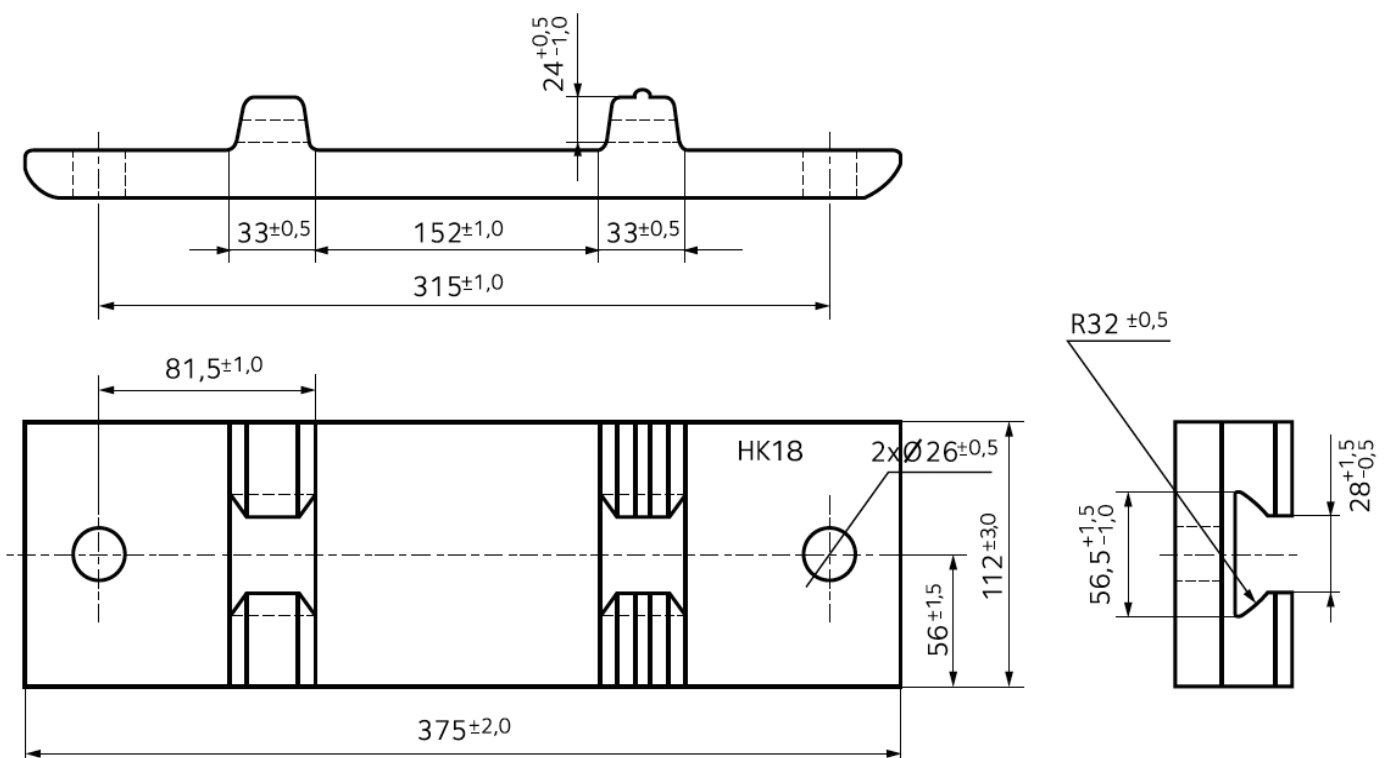



## PT180-160 from section KPT180

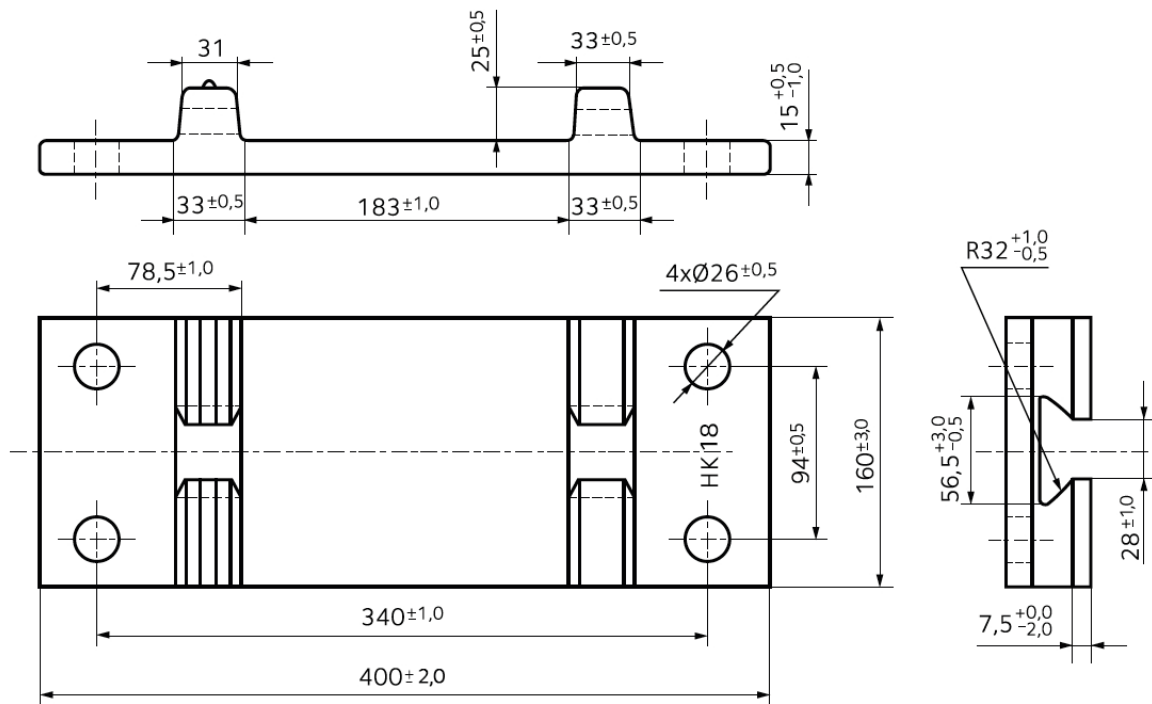

### Basides we produce

PT180-110/2/26, PT180-110/2/28

PT180-140/2/34, PT180-140/6/26

PT180-110/2/36, PT180-110/2/37

PT180-140/4/26, PT180-150/4/24

PT180-115, PT180-130, PT180-140/2/26

PT180-150/4/26, PT180-160/2/26

**Pz-a16 from section KPZ3**

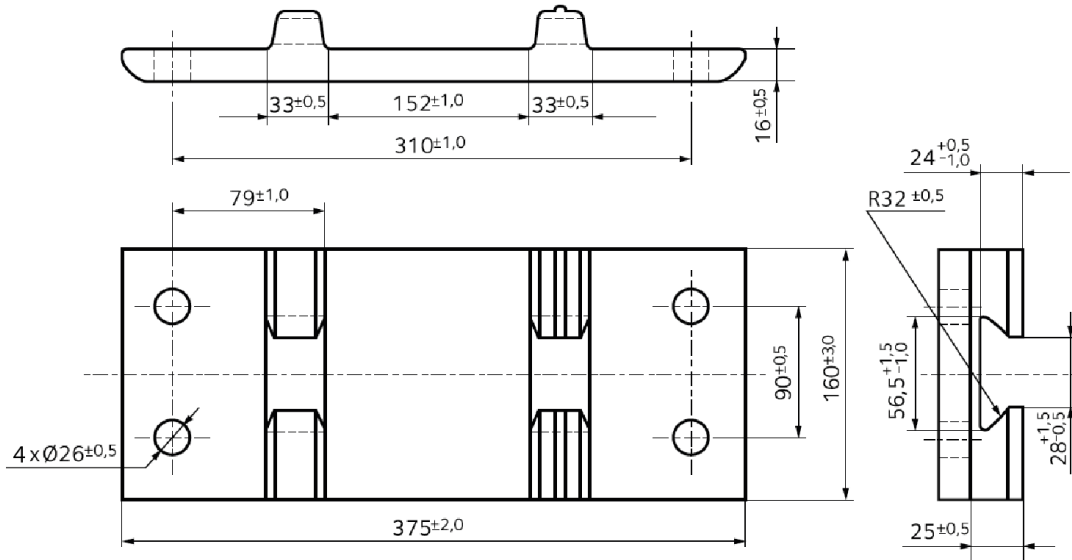

**Pzb16A from section KRp01/01**

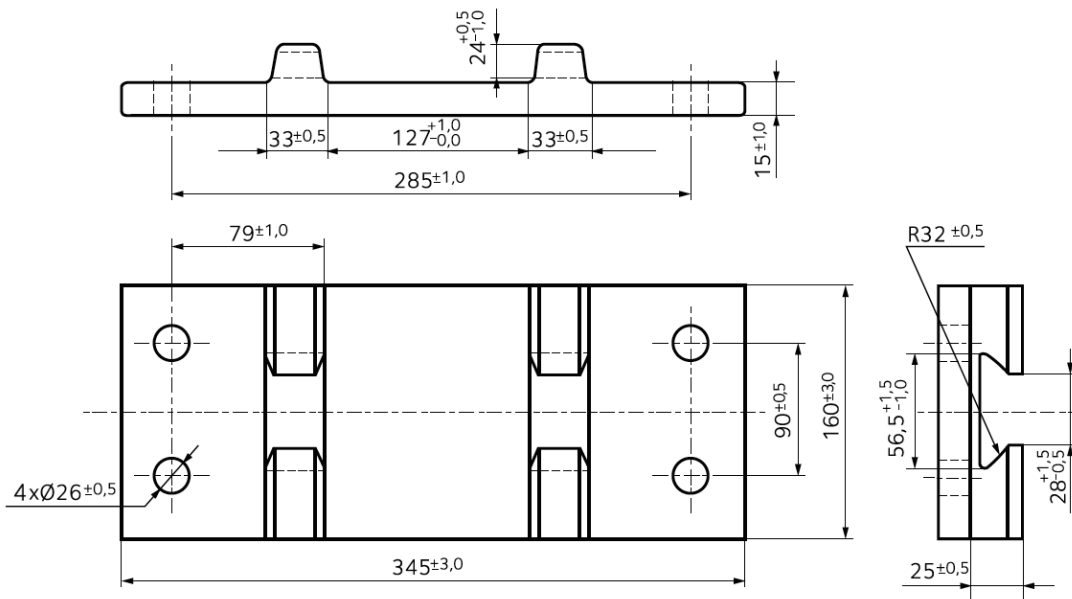

**Besides we produce**

From section KPZ3	From section KPZ3 thickness 20 mm	From section KPZ5	From section KRpo21
Pza18A	Pza16-20	Pm49-140/HR	Rpo21a, Rpo21f, Rpo21b
Ps60-160/HR	Ps60-20/112/2/26	Rpl-150, Rpl-110 n/o-,fr	
Ps60-150/4/25	Ps60-20/160/4/24	Rpo5e	
Ps60-180/4/25	Ps60-20/160/2/28	RplVx	
Ps60-210/4/26	Ps60-20/160/4/26		
	Ps60-20/180		

Rpl-20/4 from section KRp01/01B

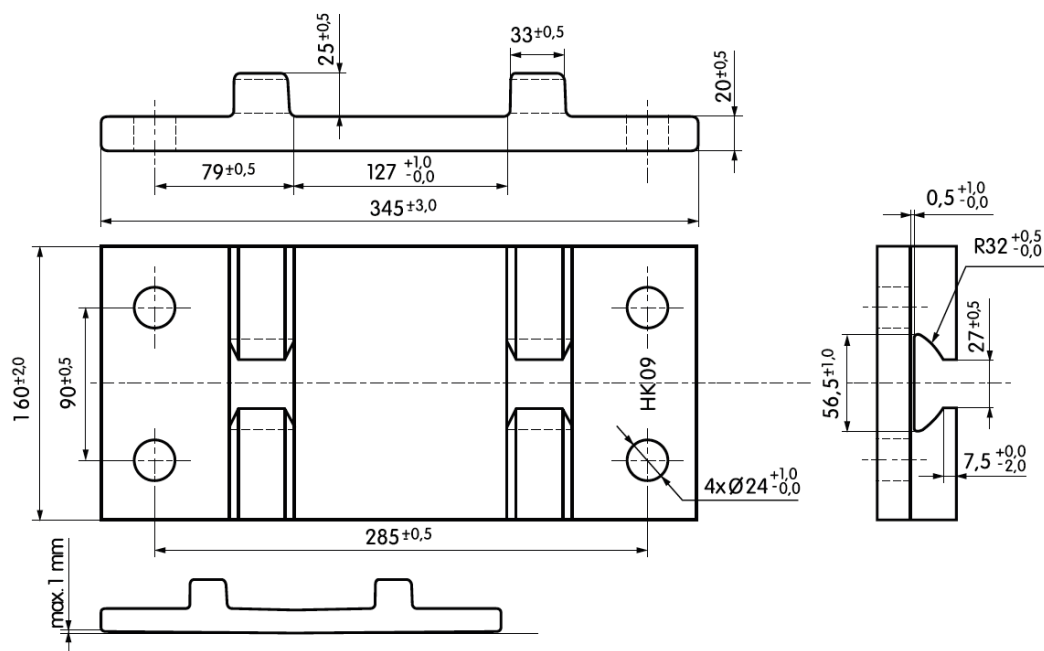

Pz-49A from section KPZ5

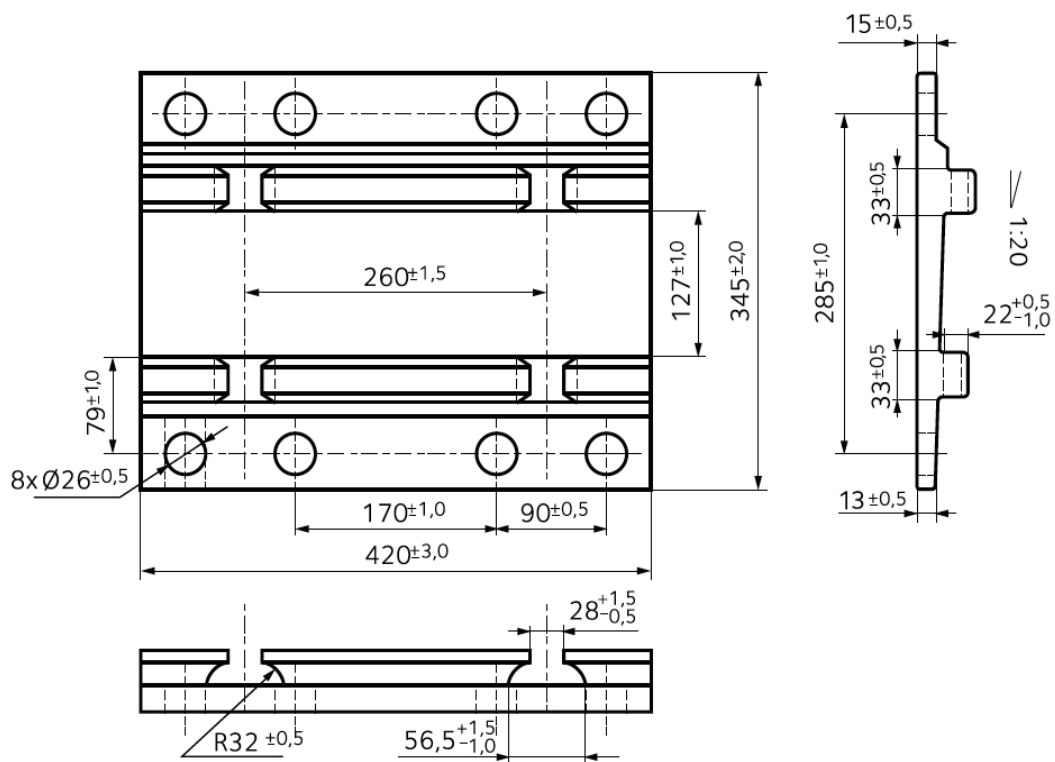

P39 from section KP39

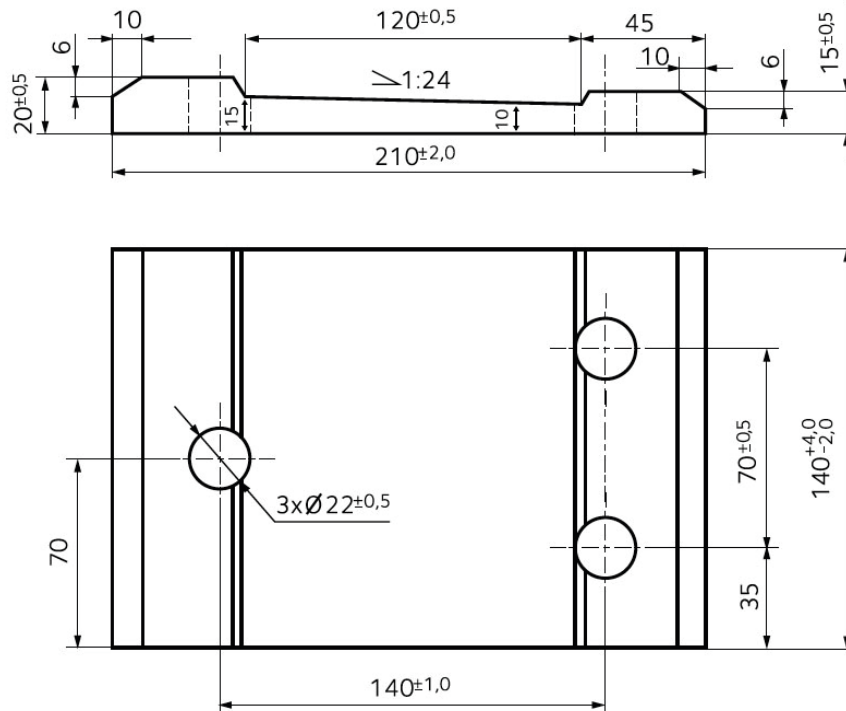

Pzb18B from section KRp01/01

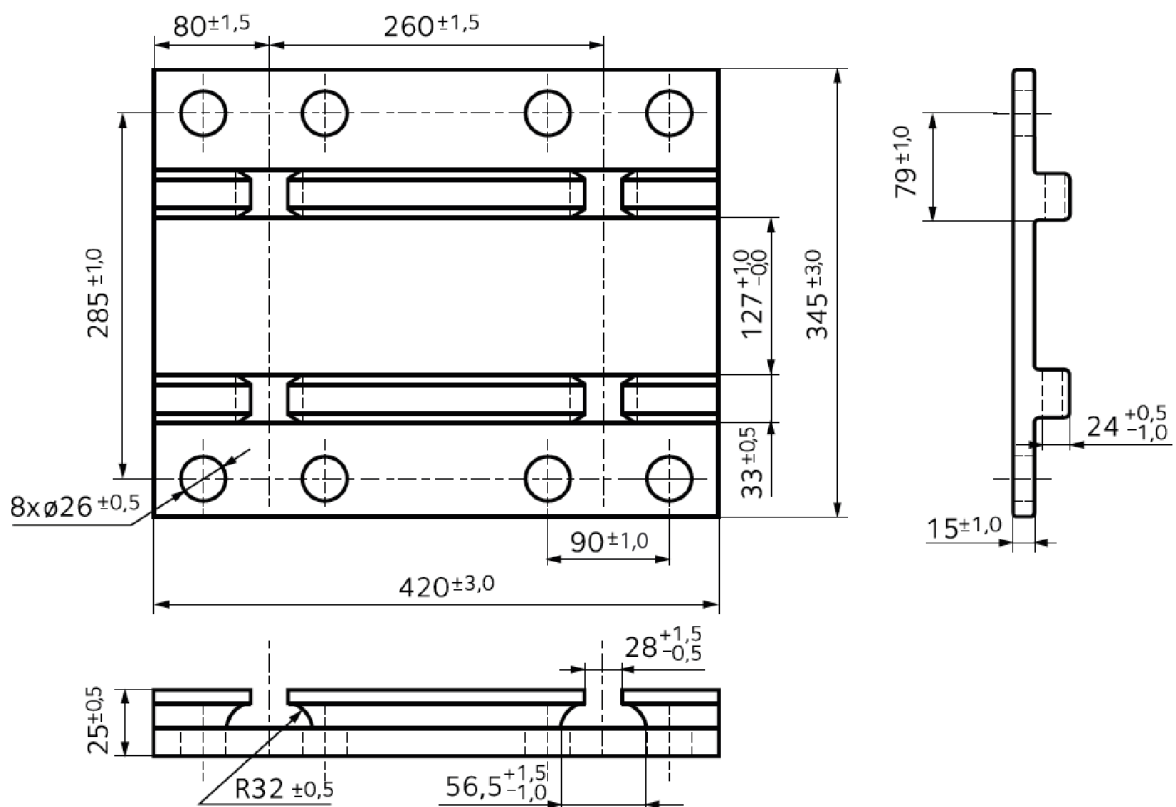

# Tie plates

## Type Pandrol

### Pandrol 140

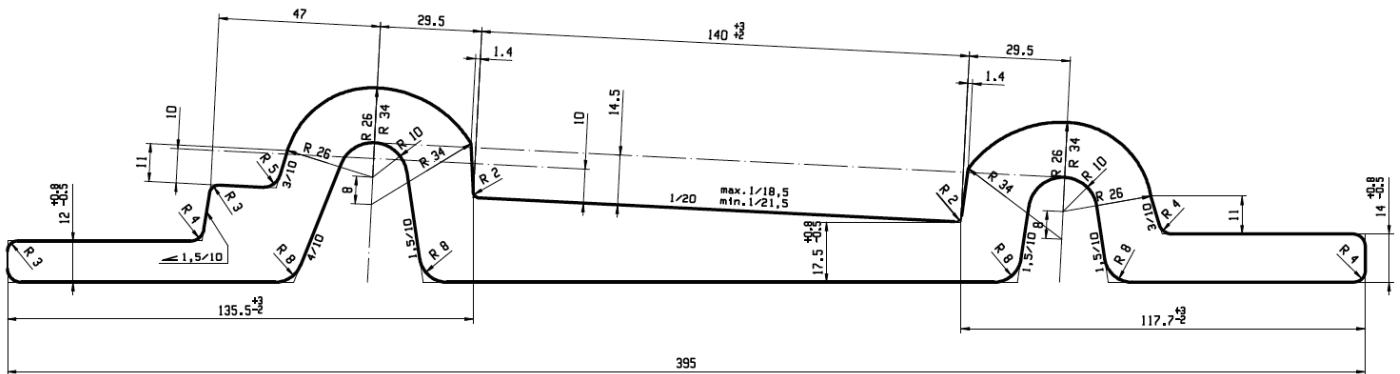

Pandrol 140 dimension B 395 mm.

Tilted Pandrol fastening 1/20

For flange rails of 140 mm.

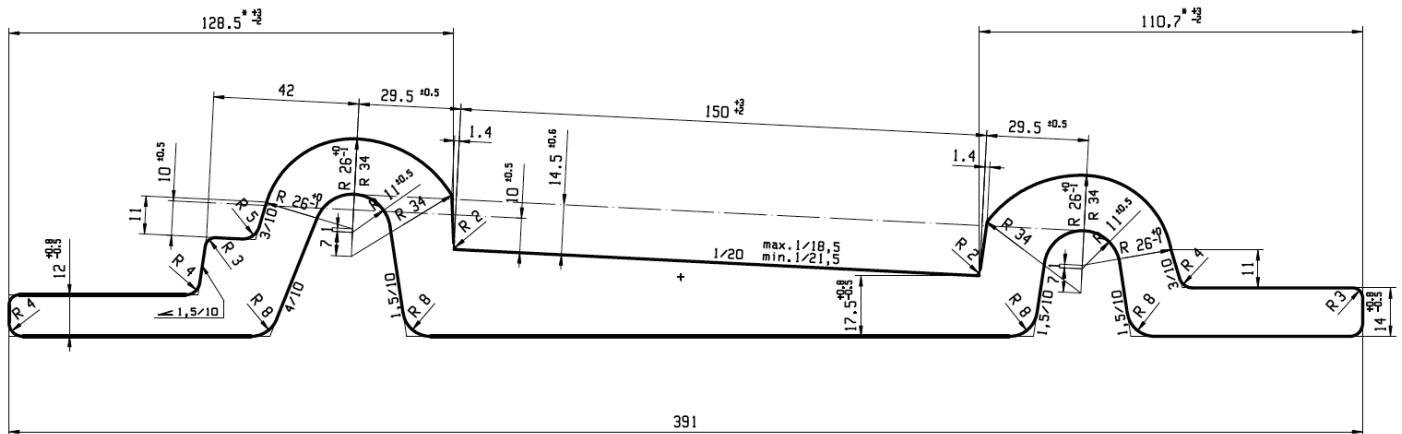

Pandrol150 dimension B 391mm.

Tilted Pandrol fastening 1/20

For flange rails of 150 mm.

\* To guarantee the functionality of the product at the joint moment, a tolerance of +6 -2.

Inclined

PI 140-1/20

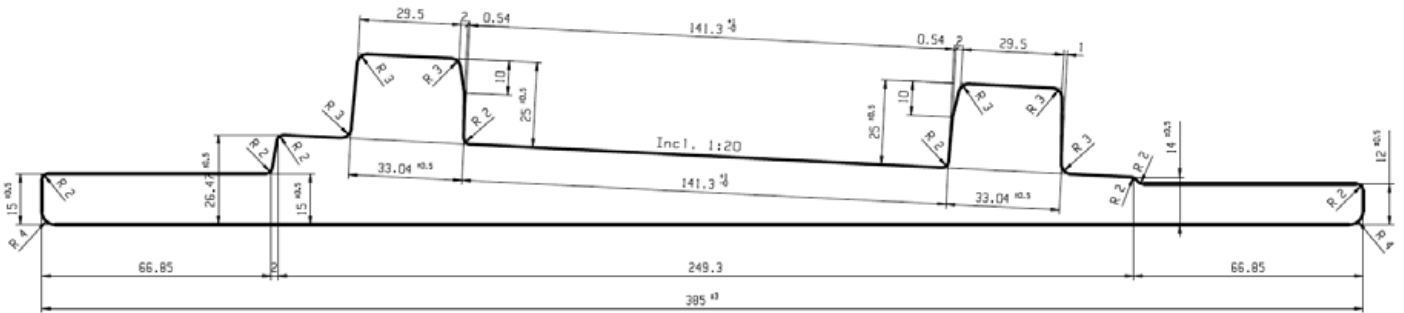

Flat inclined "GEO" 1/20 - 66,71 kg/m.  
For rails of 50 kg  
Flange rails of 140 mm.

PI 150-1/20

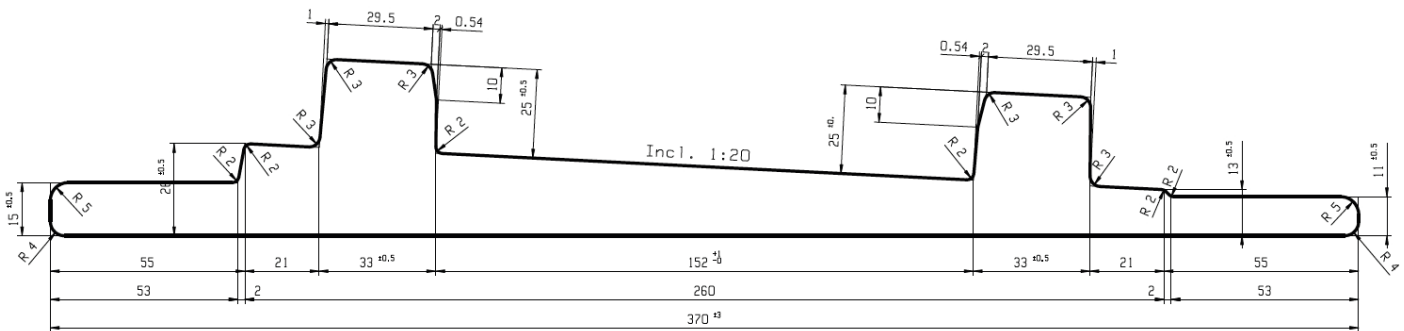

Flat inclined "GEO" 1/20 - 57.5 kg/m.  
Flange rails of 150 mm

PI 150-1/40A

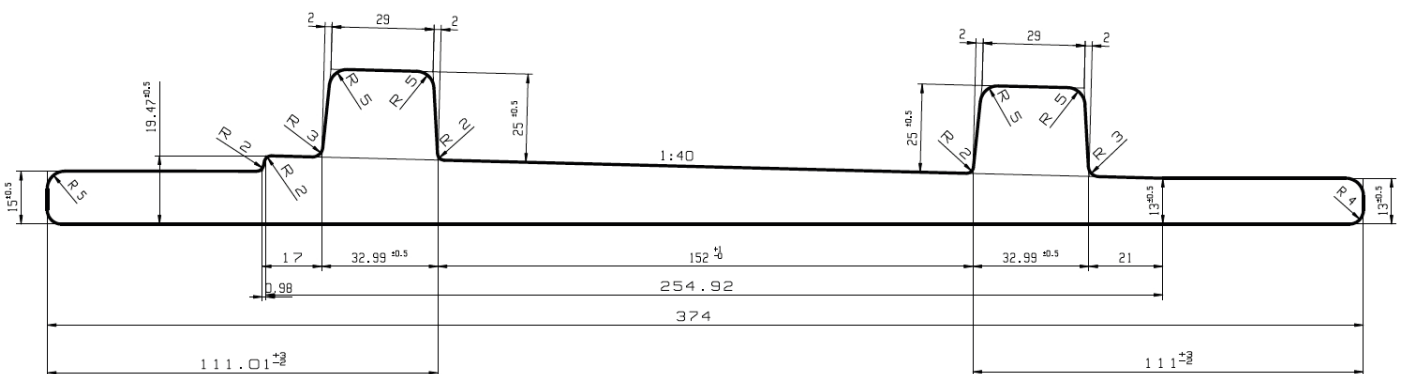

Flat inclined "GEO" 1/40 - 57.5 kg/m.  
Flange rails of 150 mm.

PI 150-1/40B

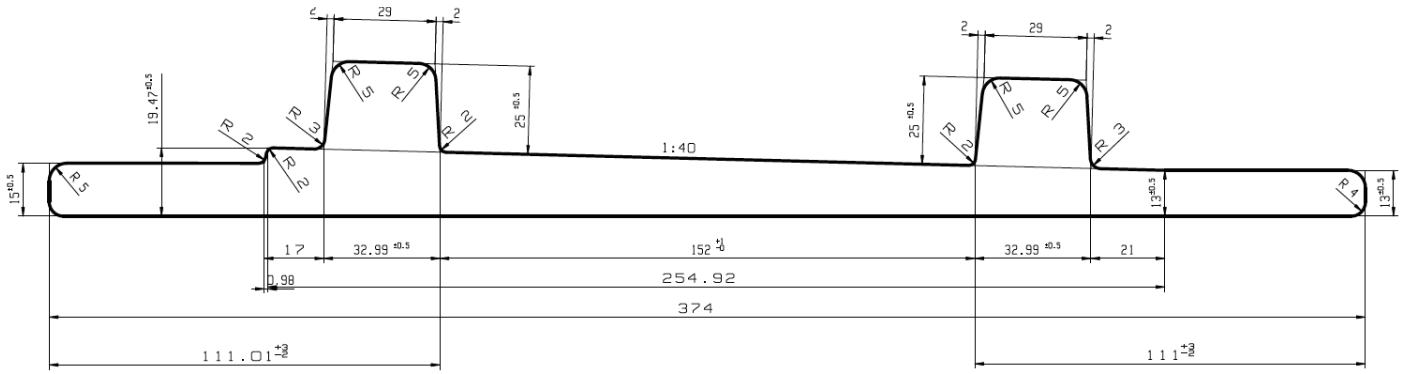

Flat inclined "GEO" 1/40 - 69,2 kg/m.  
 Flange rails of 150 mm.

Standard

PP 140-t14

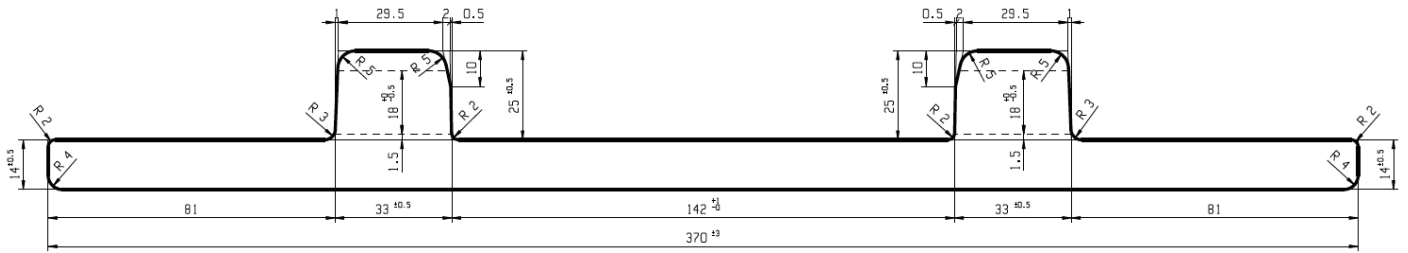

Flat plate "GEO" - 53 kg/m.  
Flange rails of 140 mm.

PP 140-t15

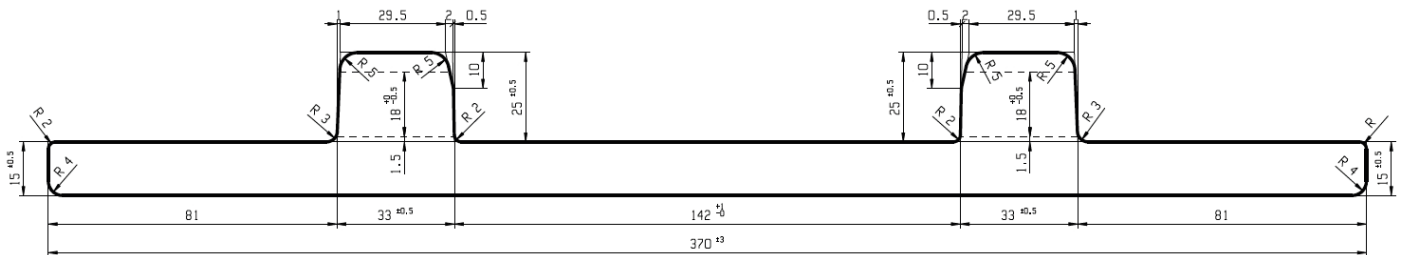

Flat plate "GEO" - 55,84 kg/m. for the S.T.I.B.\*  
Flange rails of 140 mm.

PP 140-t16

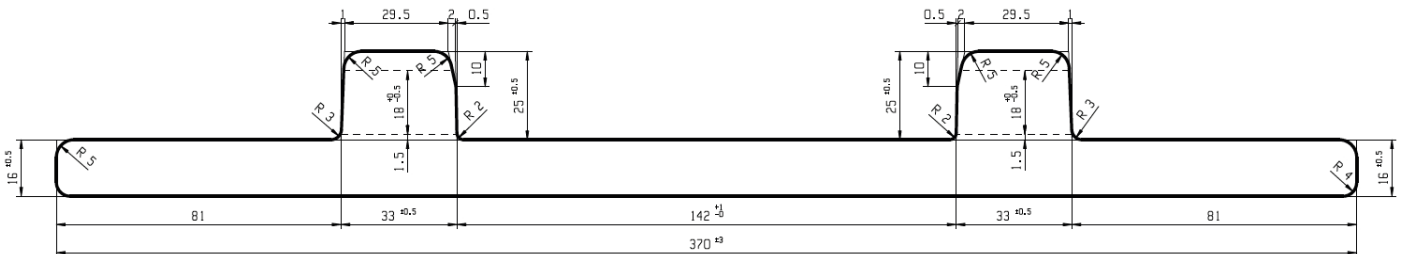

Flat plate "GEO" - 59,0 kg/m.  
Flange rails of 140 mm.



## PP 140-t20

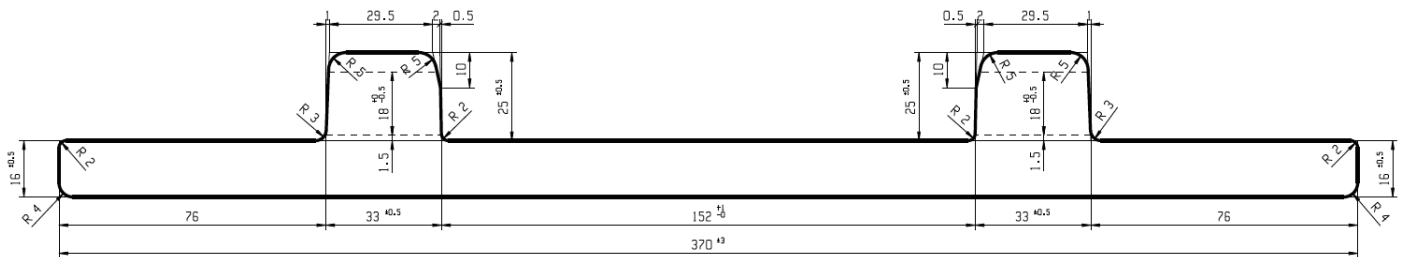

Flat plate "GEO" - 70,294 kg/m.

For rails of 50 kg Belgium state.

Flange rails of 140 mm.

- Steel grade as per the request of the customer.
- All variations upon request and subject to final acceptance of the mill.
- Delivery of all tie-plate profiles in length up to 24m possible. For length > 24m pls contact the technical department.
- All tie-plate profiles can be delivered as finished product ready for use (cut, drilled) based on the specifications of the customer.

\* S.T.I.B. Société des Transports Intercommunaux de Bruxelles.

Standard

PP 150-t15

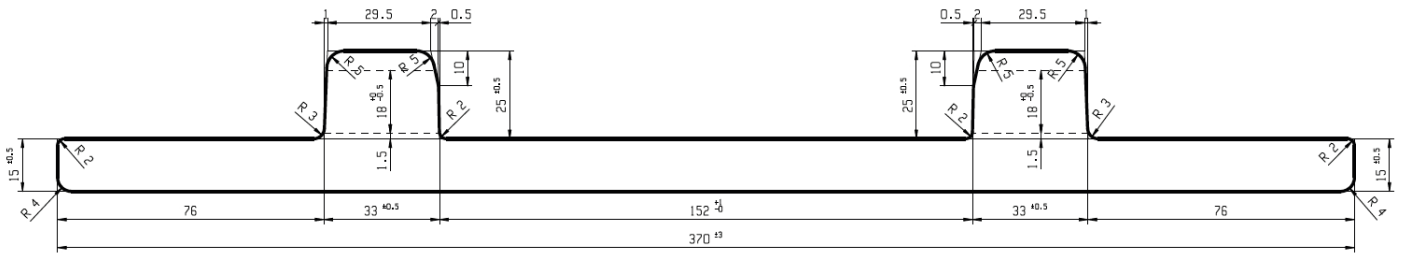

Flat plate "GEO" - 55,84 kg/m. modelo S.I.T.B.\*  
 Flange rails of 150 mm.

PP 150-t16

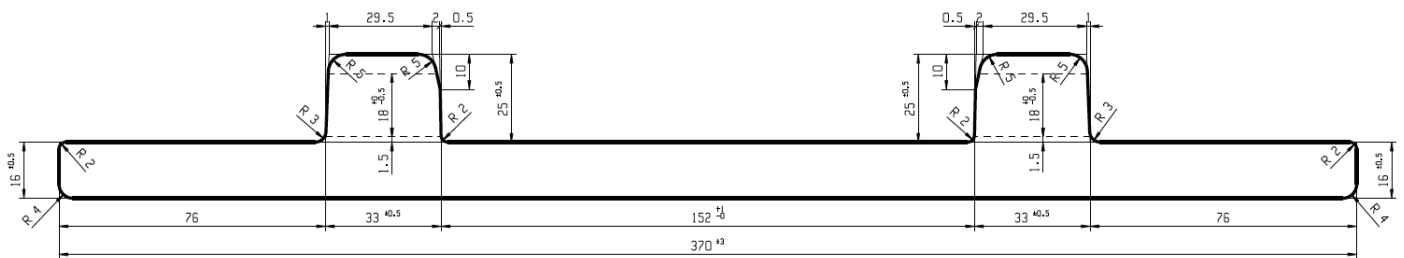

Flat plate "GEO" - 59 kg/m. modelo U.I.C.  
 Flange rails of 150 mm..

PP 150-t20

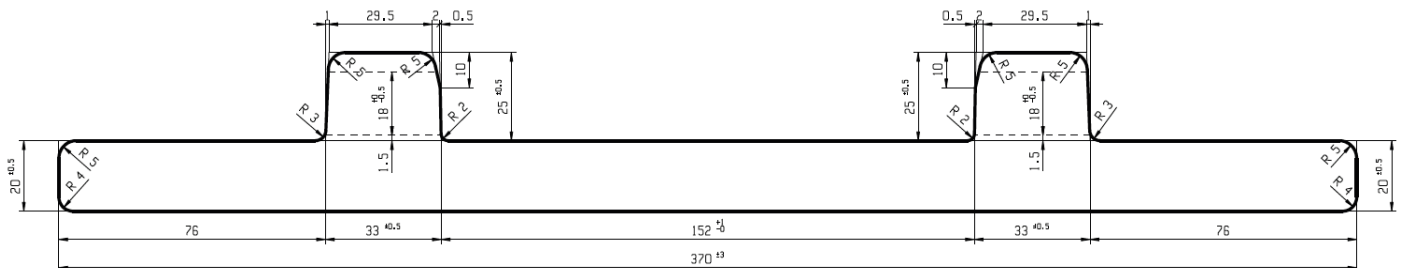

Flat plate "GEO" - 70,294 kg/m.  
 Flange rails of 150 mm.

- Steel grade as per the request of the customer.
- All variations upon request and subject to final acceptance of the mill.
- Delivery of all tie-plate profiles in length up to 24m possible. For length > 24m pls contact the technical department.
- All tie-plate profiles can be delivered as finished product ready for use (cut, drilled) based on the specifications of the customer.

\* S.T.I.B. Société des Transports Intercommunaux de Bruxelles.

# Clamps

Ł p2

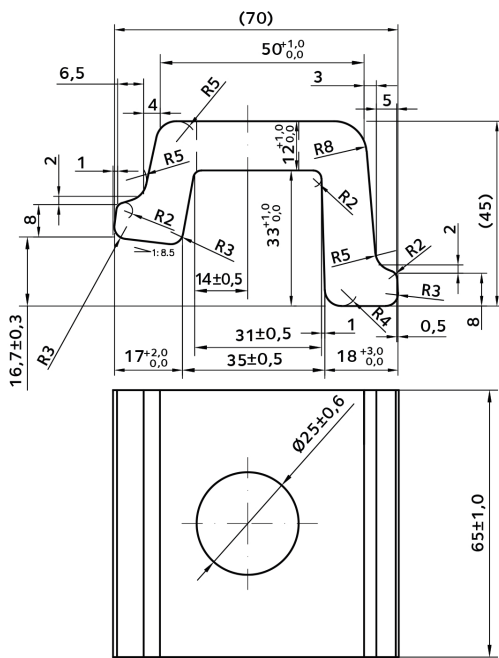

Ł p3

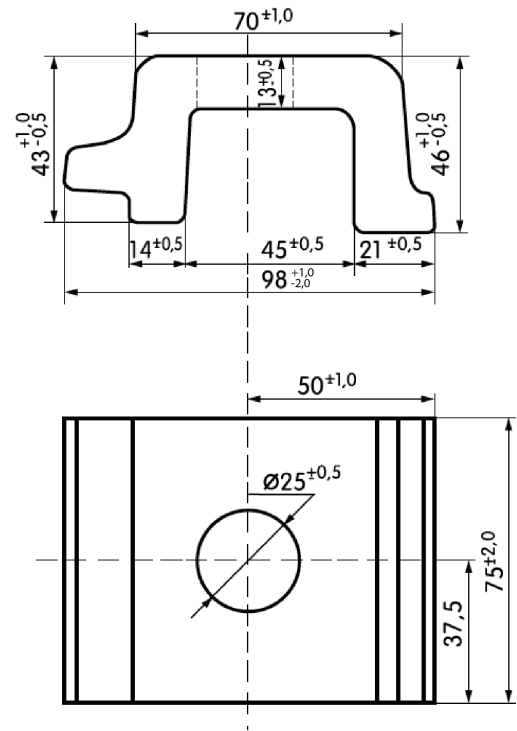

Ł p5

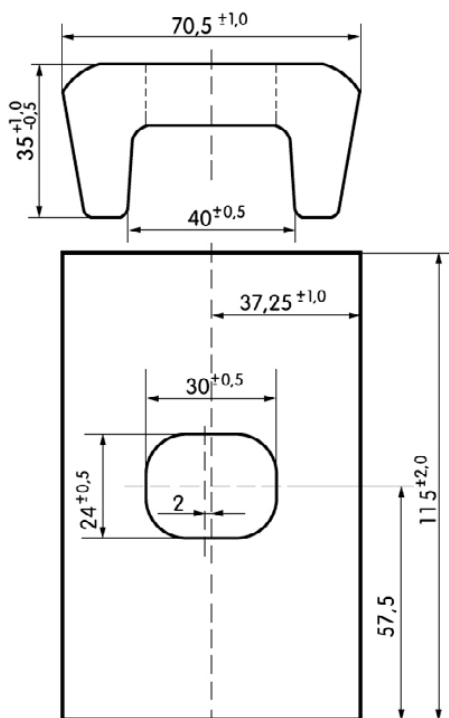

Ł p06

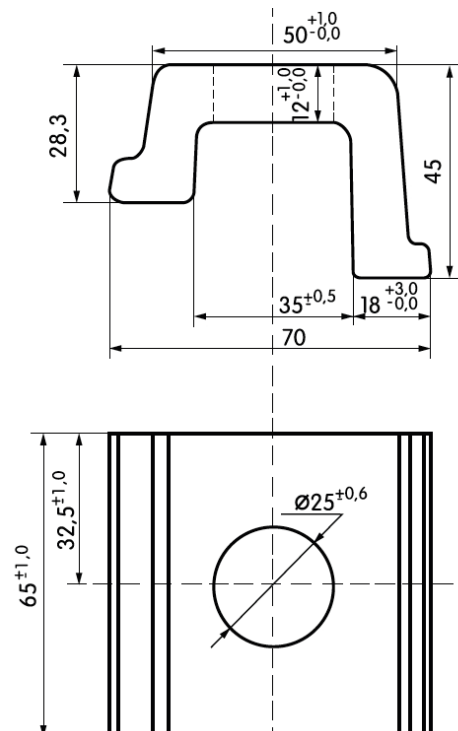

# Fishplates

FI 14c

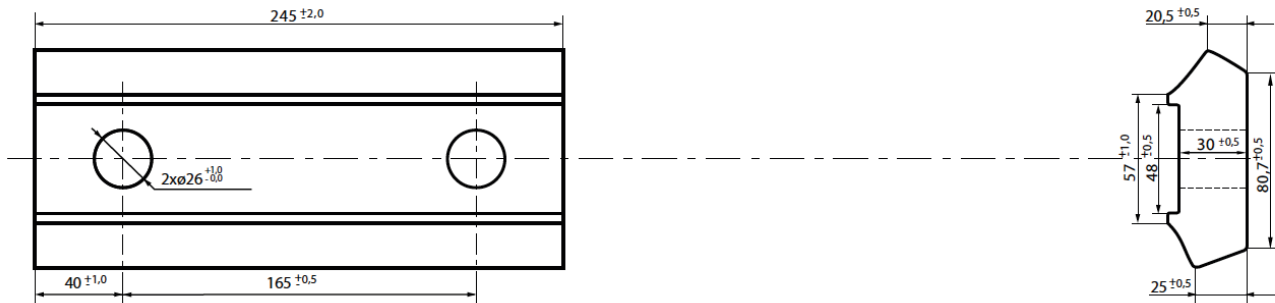

FI 14a

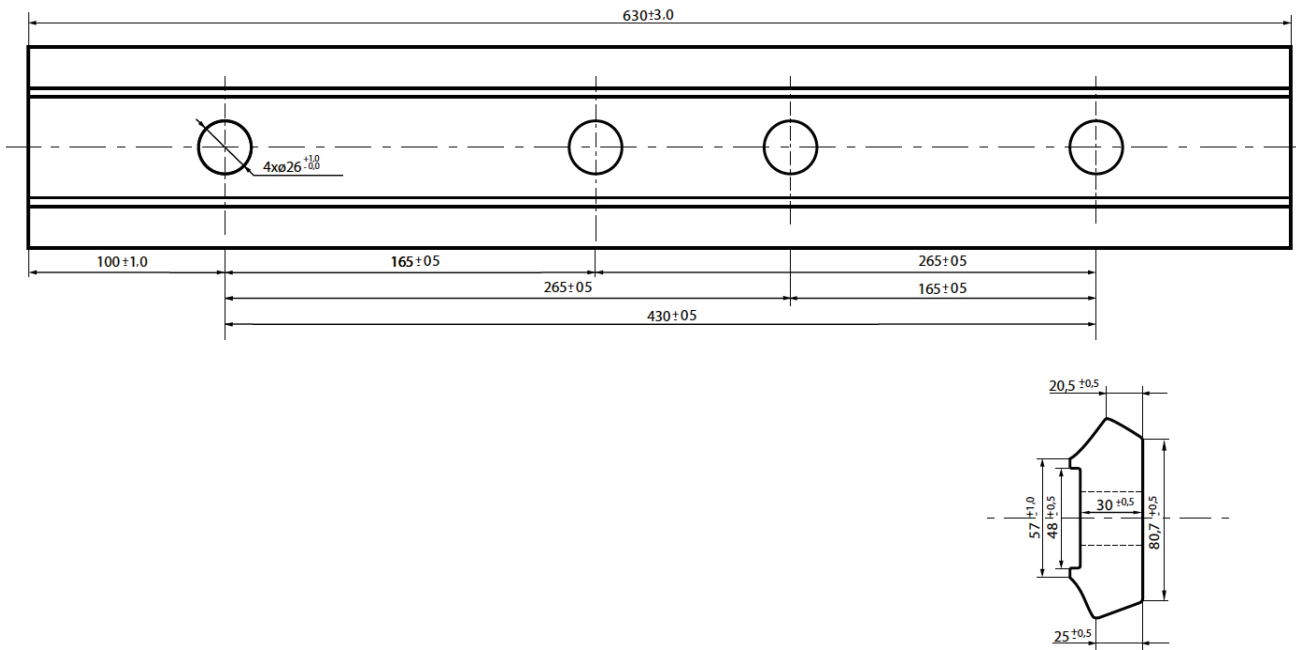

FI 30

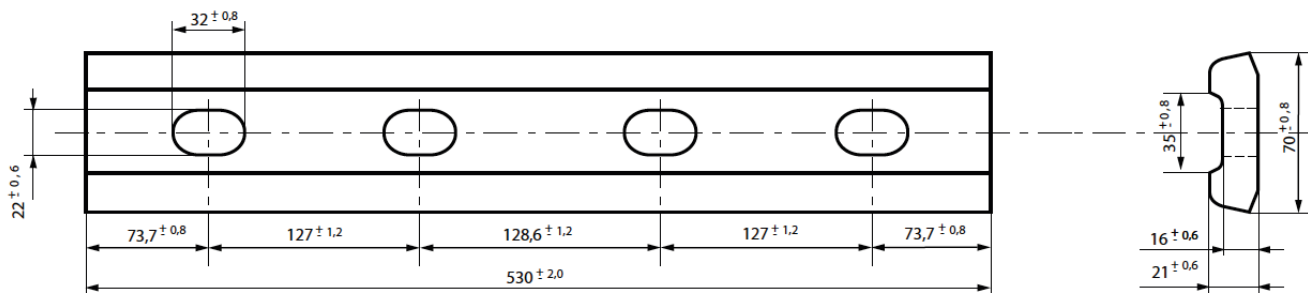

## Ł 49

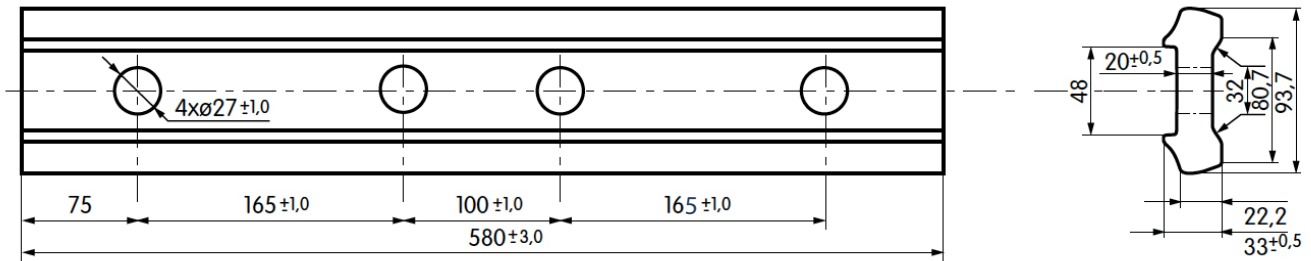

As well as Ł49/26 ( $4 \times \varnothing 26 - 0,0$ ) and / y Ł49/HR ( $4 \times \varnothing 26$ )

## Ł 49-900/6

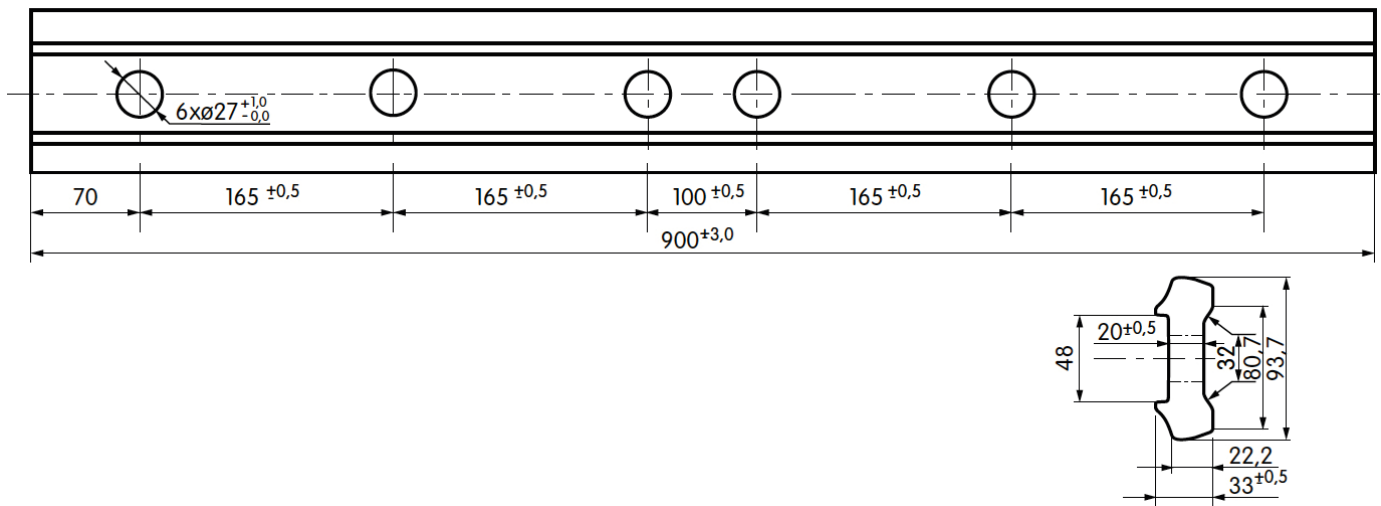

## Ł 49d



## Ł 49d-263

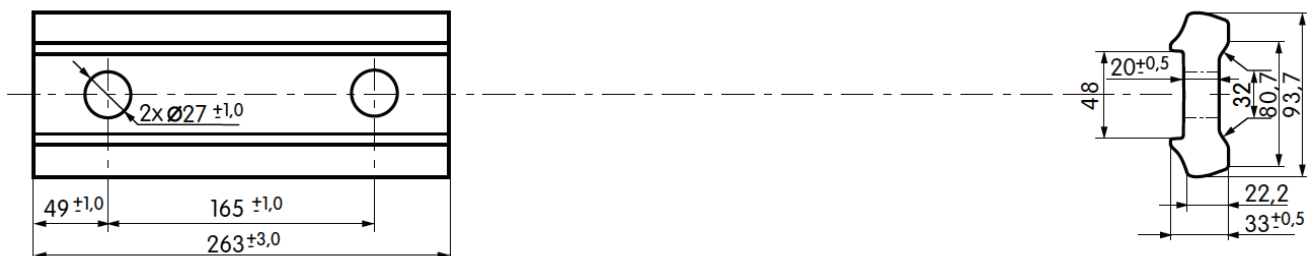

Ł 39

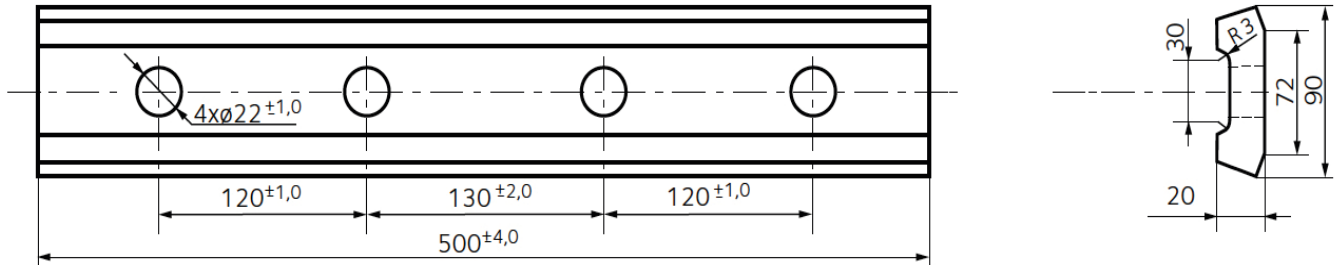

Ł 49-545/28

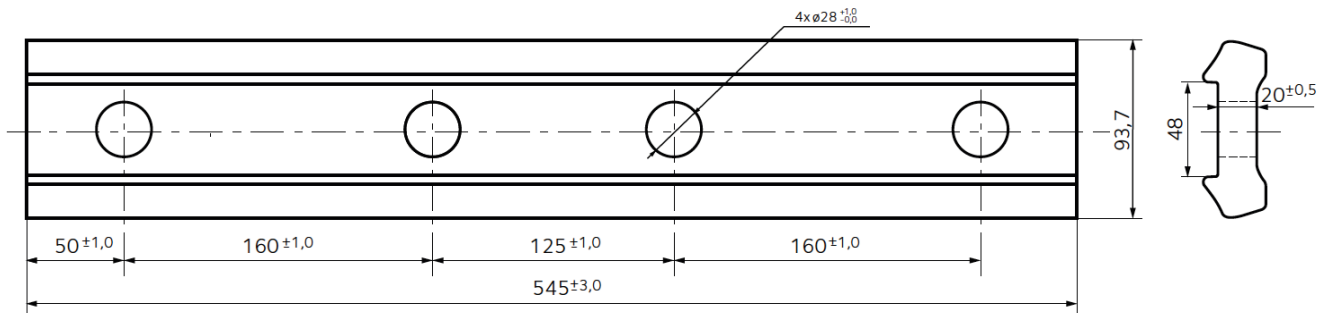

# Frog profile

## C.C.332

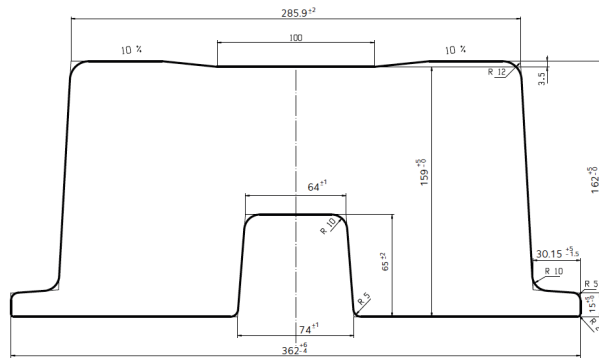

## C.C. 379

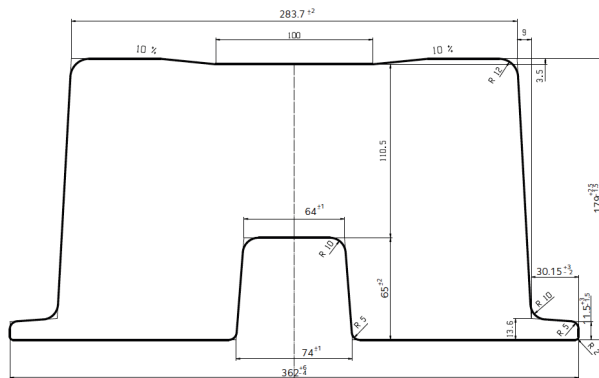

## C.C. 397

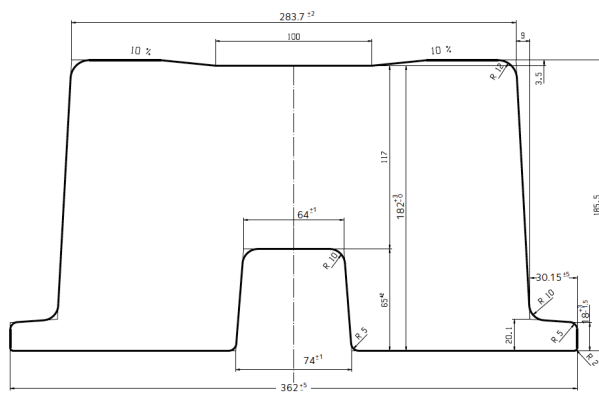

CC332, CC 379 and CC 397

Steelgrades as per request.

Length as per request.

Used to build cross sections between rails

# Metro guide bar

Angle of the guide and of the outlet

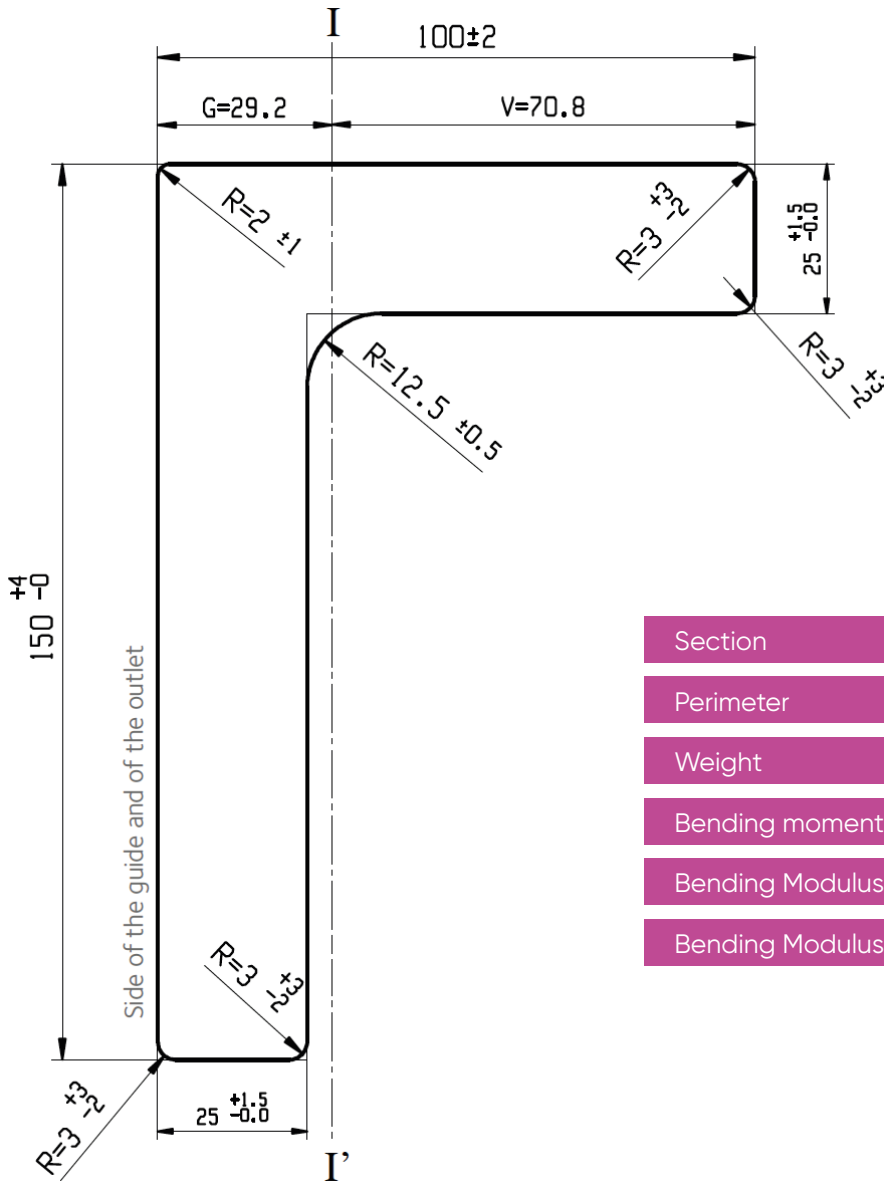

Section	56.50 cm <sup>2</sup> .
Perimeter	488.6 mm.
Weight	44.35 kg/m.
Bending moment of inertia I-I'	417.8 cm <sup>4</sup> .
Bending Modulus I/V	58.9 cm <sup>3</sup> .
Bending Modulus flex I/G	146.6 cm <sup>3</sup> .

Bar dimensions 150 x 100 x 25 mm Weight: 44,35 kg/m.  
Low-resistivity steelgrade (LR-Grade).

Used in the construction of metro lines to limit the lateral movements of the wagons and to enable the current flow.



# Base plates

UIC54-170

produced from section type KUIC54

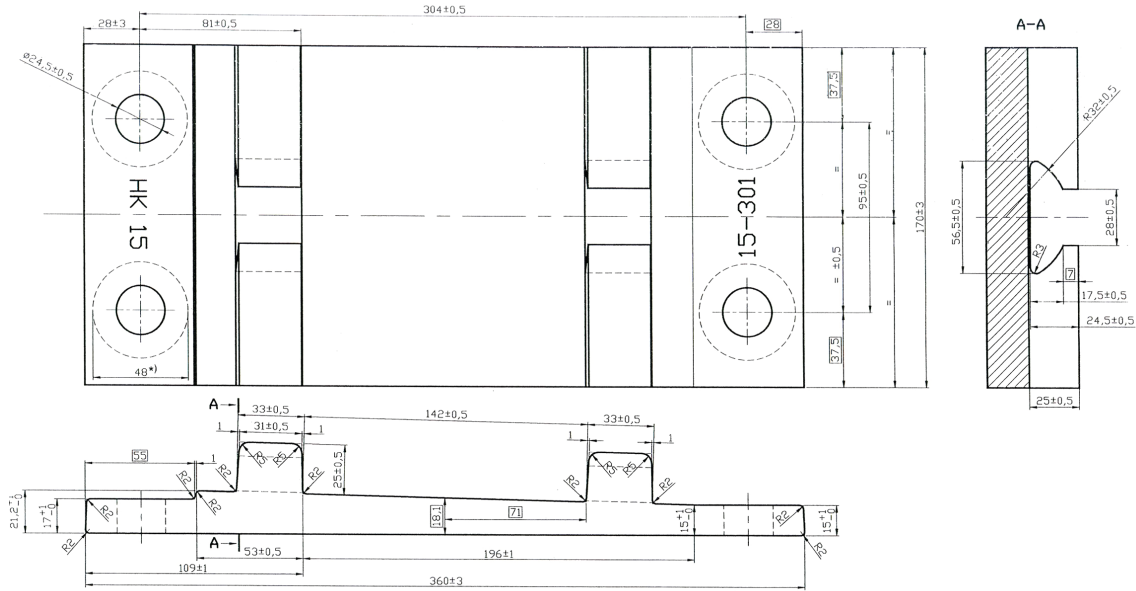

54E1-160

produced from section type 54E1

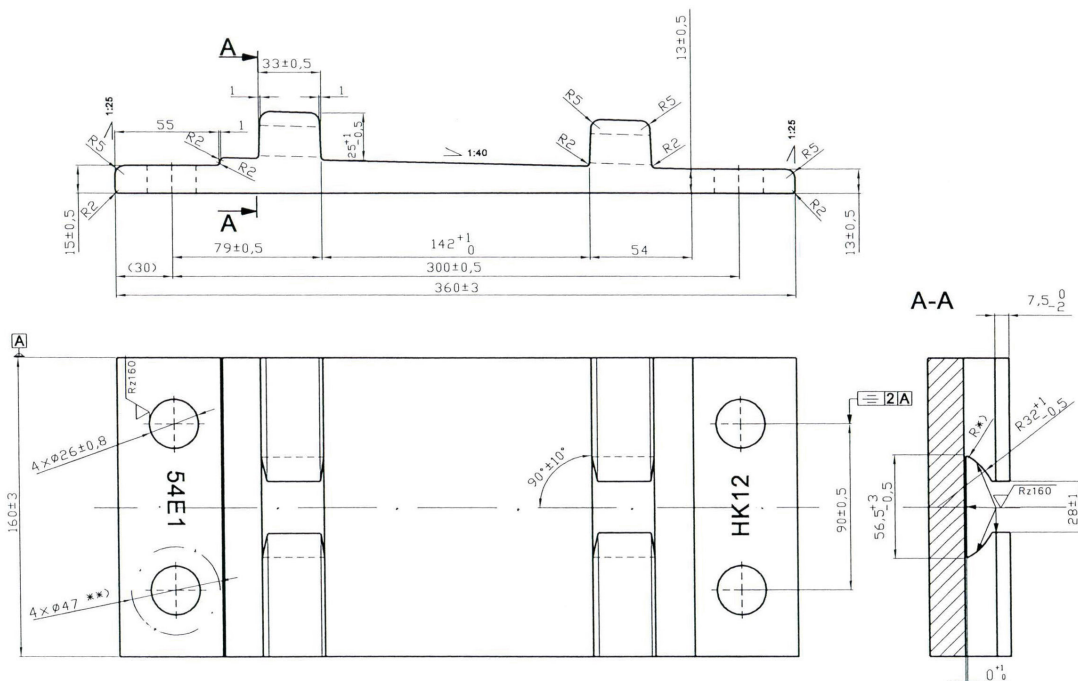

# Strengthened fishplates

Ł60W4

produced from section type KŁ60W

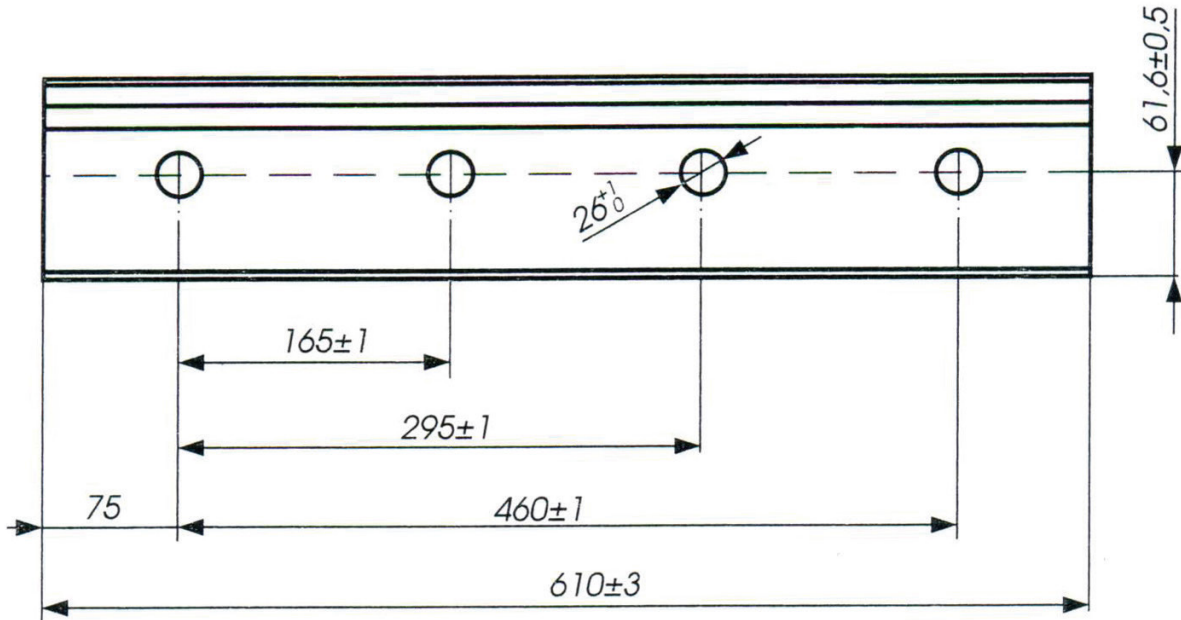

Ł60W6

produced from section type KŁ60W

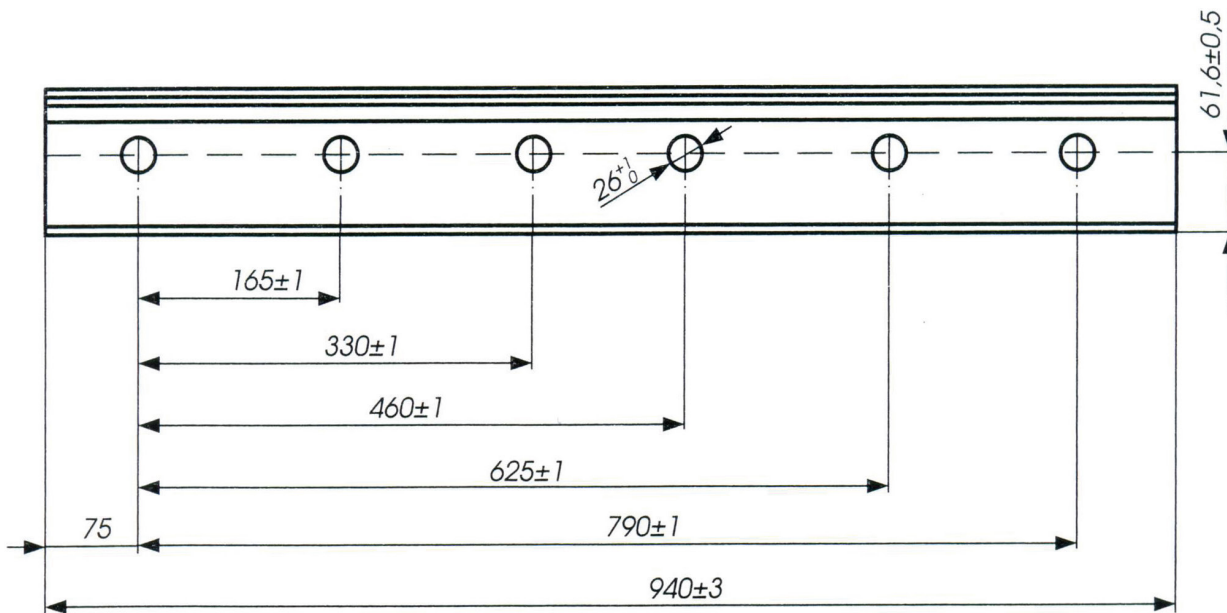

Ł49W4

produced from section type KŁ60W

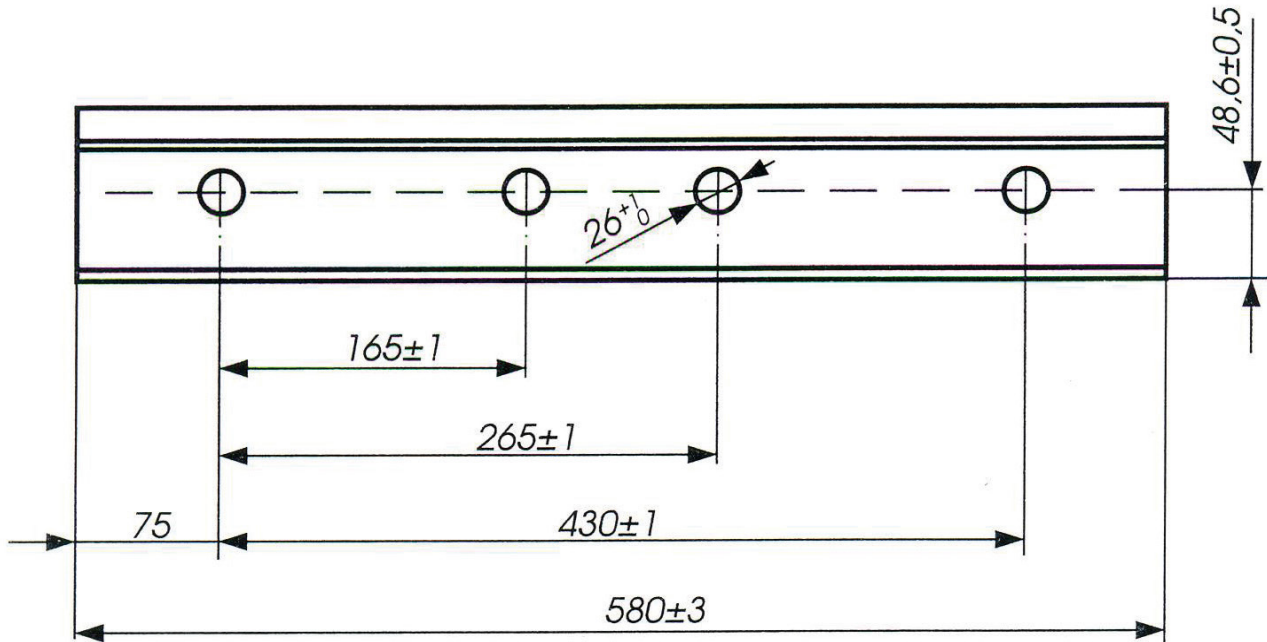

Ł60W6

produced from section type KŁ60W

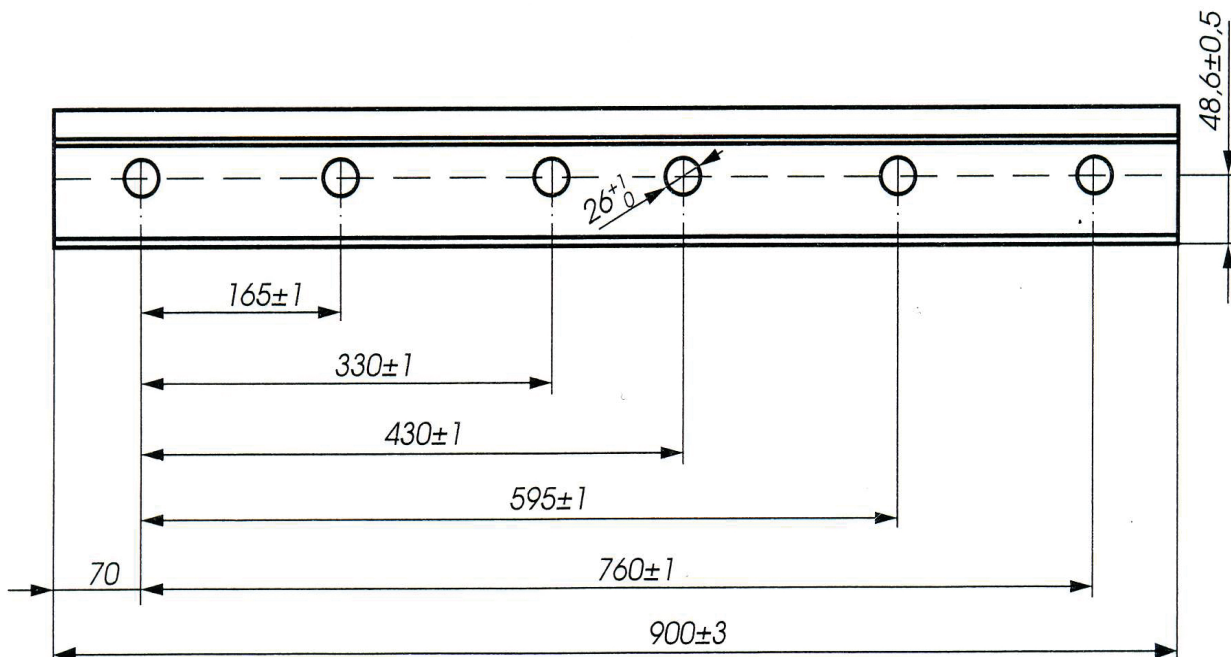

Ł60WS4

produced from section type KŁ60WS

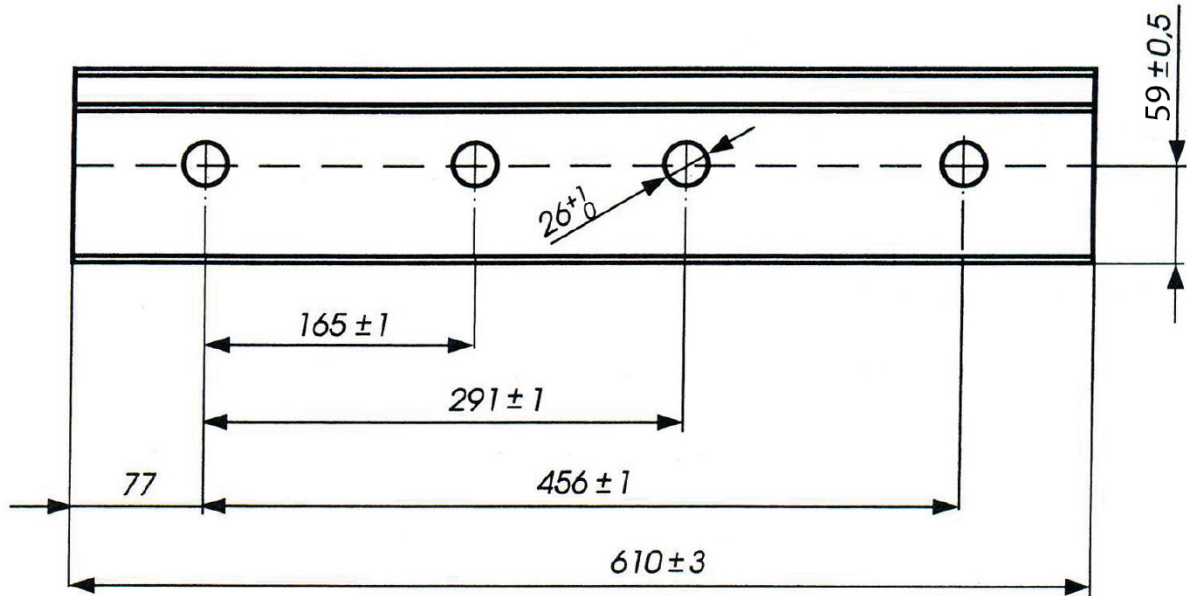

Ł60WS6

produced from section type KŁ60WS

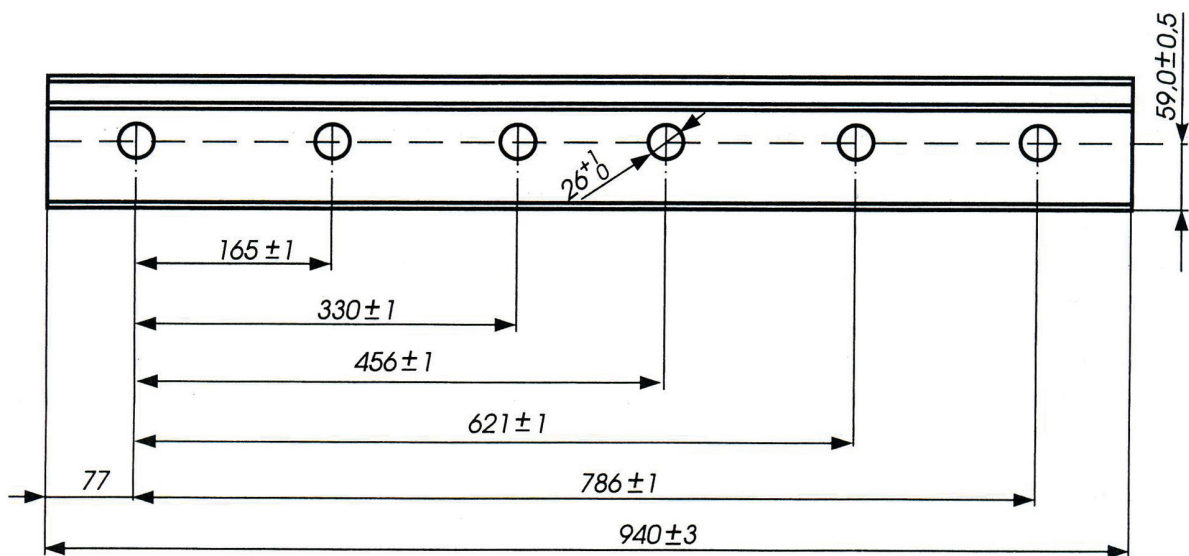

Ł49WS4

produced from section type KŁ49W

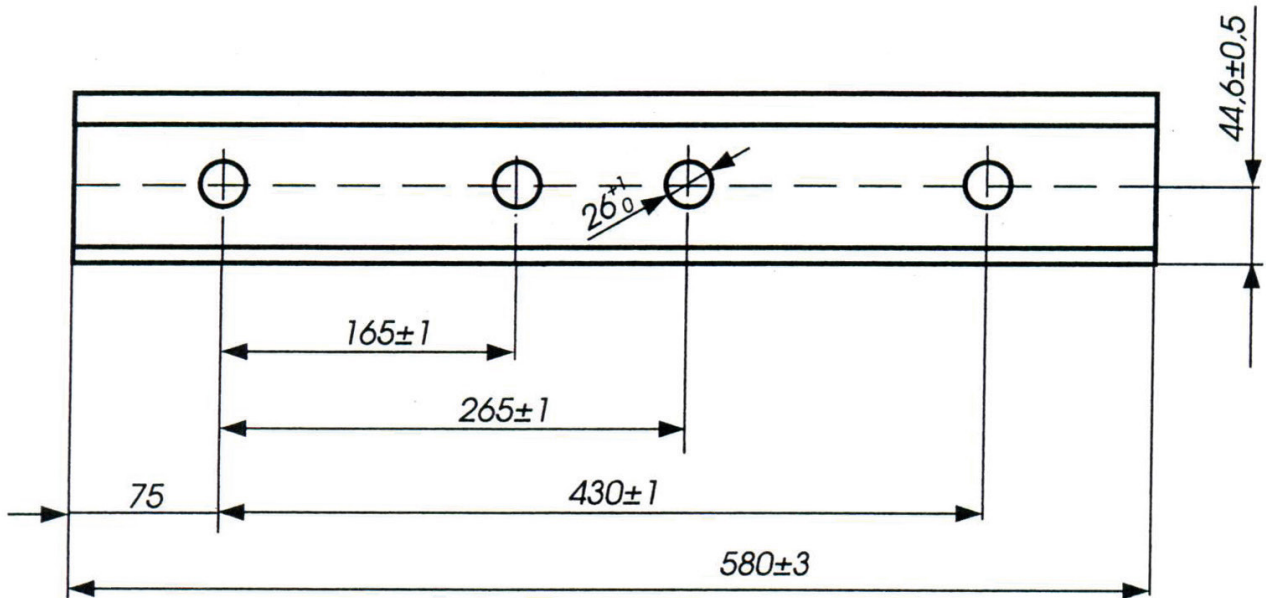

Ł49WS6

produced from section type KŁ49W

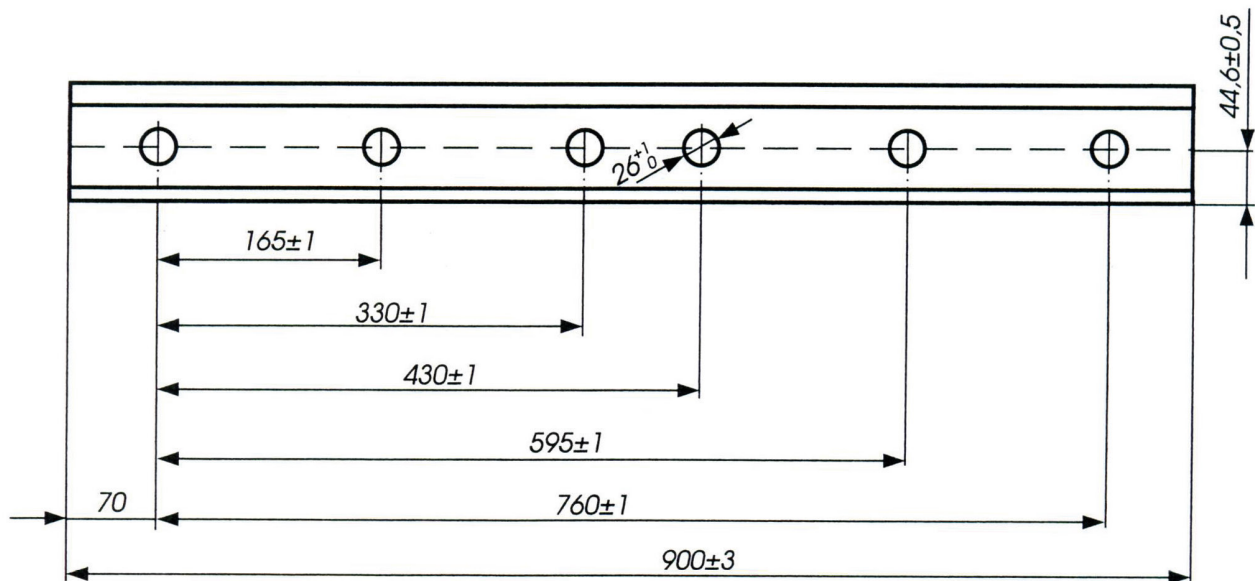

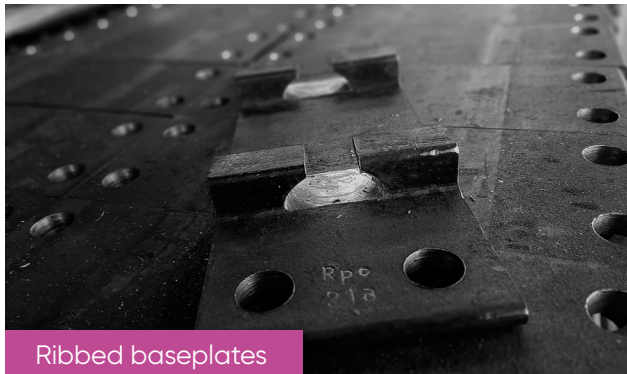

### Quality products and service

The high quality of our rails, linked with awarded customer quality certificates and homologations (for example DB in Germany and DEKRA Rail in the Netherlands), are the reasons for which our products have experienced an important increase in the global market in the recent years with worldwide sales.

ArcelorMittal Rails quality policy is focused on ensuring our customers the quality of our products supply, adapted specifically to their needs. Our quality assurance system policy is intended for the production of rail and rendering of services according to the changing needs of our customers, in order to meet or exceed their expectations.

Customer satisfaction is our main objective and the prevailing condition for permanent success of our rail facilities and product reliability

## ArcelorMittal Global R&D

In ArcelorMittal we are permanently committed to improving rail steel quality, production and new developments. The development of new materials starts with a design of new material, continues with the fabrication and testing of the prototypes and ends with real test track.

To carry out such process, ArcelorMittal Global R&D designs and builds different equipment, such as for advanced laboratory testing and in-use properties control (twin-disk and real size Rolling Contact Fatigue Bench).

In addition, there is a pilot welding plant with: aluminothermic welding equipment, preheating devices and specific repair welding equipment, among others. The rail welding research line has extensive experience in finite element simulation of rail joining processes, which allows us to advance on specific procedures adapted to the new rail grades.

Once the rail is installed on track, a monitoring of the most relevant parameters is carried out. This monitoring of the performance may include hardness, wear, rolling contact fatigue or corrosion evolution.

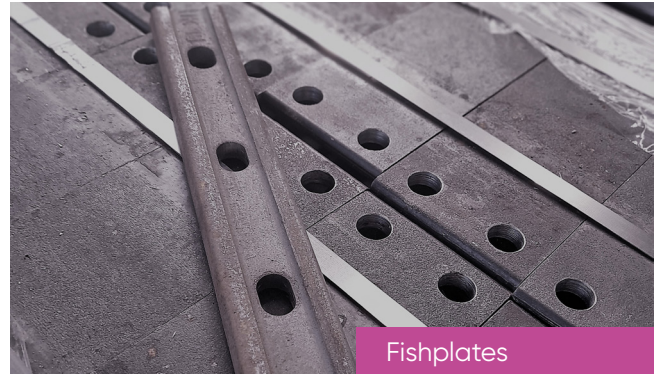



ArcelorMittal

**ArcelorMittal Commercial Long Poland**

Sales | Rails | Al. Piłsudskiego 92

41-308 Dąbrowa Górnicza, Poland

halina.krawczyk@arcelormittal.com

Tel: +48 327 767 996

rails.specialsections@arcelormittal.com

**ArcelorMittal Commercial Sections**

Sales | Special Sections | 66, Rue de Luxembourg

L-4221 Esch sur Alzette | G.D. of Luxembourg

rails.specialsections@arcelormittal.com



[rails.arcelormittal.com](https://rails.arcelormittal.com)